

MANUAL

T1061, T1561

Temperature Sensors for Plastic Industry and Bearings
with Flexible Steel Conduit



- Measuring resistor 1× / 2× Pt100, thermocouple 1× / 2× “J”, “K”.
- Measuring range -50 to +400 °C.
- Accuracy class A, B according to EN 60751, 1, 2 according to EN 60584-1.
- Spring-loaded measuring stem.
- Full stainless steel design including flexible protective conduit.
- Optional diameter of measuring stem.
- Optional length of protective conduit.
- Housing IP 64 (sensor), IP 40 (flexible protective hose).

Obsah

1. Obecné pokyny a informace.....	3	4. Pokyny pro instalaci, obsluhu a údržbu.....	6
1.1 Použité symboly	3	4.1 Instalace a uvedení do provozu.....	6
1.2 Bezpečnostní upozornění a varování.....	3	4.2 Obsluha a údržba	6
1.3 Rozsah dodávky.....	3	5. Parametry výrobku.....	7
1.4 Popis dodávky a balení.....	3	5.1 Technické parametry.....	7
1.5 Skladování	3	5.2 Provozní podmínky.....	7
1.6 Instalace, obsluha a údržba	3	5.3 Metrologické parametry.....	7
1.7 Náhradní díly	3	6. Objednání	8
1.8 Opravy	3	6.1 Objednací tabulka.....	8
1.9 Záruka.....	3		
2. Ukončení provozu a likvidace	4		
2.1 Ukončení provozu.....	4		
2.2 Nakládání s obaly a likvidace.....	4		
3. Popis výrobku.....	5		
3.1 Použití.....	5		
3.2 Popis	5		
3.3 Rozměrové nákresy.....	5		

1. General instructions and information

1.1 Symbols used



Symbol of warning; for safe use it is necessary to proceed according to the instructions



This product does not belong to public waste and it is subjected to separate collection

1.2 Safety warnings and cautions



The equipment may be installed only by a qualified personnel who are familiar with national and international laws, directives, standards and with the instructions manual. The equipment shall be supplied from a safe voltage source that meets all requirements of the standard EN 61010-1 and must be installed in compliance with national requirements and standards providing safety.

The instrument may not be used for other purposes than as specified in this instruction manual. For elimination of a risk of injury from electric shock or fire, the maximum operational parameters of the instrument may not be exceeded.

1.3 Scope of delivery

With the product is delivered:

- Manual for installation, operation and maintenance
- Certificate of calibration (only with calibrated sensors)

1.4 Description of the delivery and packing

The product is packaged in a protective cover and provided with an identification label with a mark of the output control.

The product must not be exposed to direct rain, vibrations and shocks during transport.

1.5 Storage

The product shall be stored at temperatures from +5 to +35 °C and maximum relative humidity 80 % in the rooms with elimination of condensation of water vapours on the products. The stored products shall not be exposed to any shocks, vibrations and effects of harmful vapours and gases.

1.6 Installation and commissioning

During installation, commissioning, operation and maintenance follow the instructions in chapter 4.

1.7 Spare parts

Any of the compact parts of the product can be also ordered as a spare part if there are not required special procedures or technological operations for the exchange.

1.8 Repairs

Products are repaired by the manufacturer. The products for repair should be sent in a packing that guarantees damping of shocks and vibrations and protects against damage during transport.

1.9 Warranty

Products are covered by a warranty for a period of 24 months from the delivery date on the delivery note. The manufacturer guarantees technical and operational parameters of the products within scope of the applicable documentation. Warranty period is specified with individual items and begins

from the day of takeover of the goods by the purchaser or delivery to the carrier. Any claims concerning to defects of the goods together can be filed in writing with the manufacturer within the warranty period and the claimed product shall be presented. The claiming party shall give identification of the product, number of the delivery note and description of the fault or defect.

The manufacturer is not responsible for any defects caused by improper storage, incorrect connection, damages caused by external effects, in particular by effects of factors with excessive values, unqualified installation, improper operation or common wearing.

2. End of service and disposal

2.1 End of service



Before removing and ending of service of the sensor is at first necessary to switch the control loop to manual operation, or take other appropriate action to prevent potential harm associated with the end of sensor operation. Connected power supply is switched off and connecting wires of the sensor are disconnected (cut off).

2.2 Disposal



The products do not contain any environmentally hazardous parts. When disposing the packing and destroyed or irreparably damaged product proceed according to the local regulations.

3. Product description

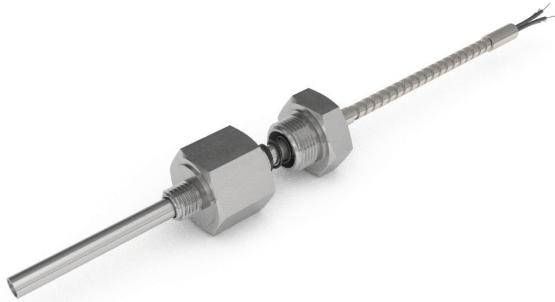

T1061, T1561 Temperature Sensors for Plastic Industry and Bearings with Flexible Steel Conduit

- Measuring resistor 1× / 2× Pt100, thermocouple 1× / 2× “J”, “K”.
- Measuring range -50 to +400 °C.
- Accuracy class A, B according to EN 60751, 1, 2 according to EN 60584-1.
- Spring-loaded measuring stem.
- Full stainless steel design including flexible protective conduit.
- Optional diameter of measuring stem.
- Optional length of protective conduit.
- Housing IP 64 (sensor), IP 40 (flexible protective hose).

3.1 Application

Resistance and thermocouple temperature sensors T1061 and T1561 are designed for temperature measurement in solid materials where a hole and inner screw-thread for sensor installation can be drilled. It is primarily plastics forms, bearing houses, engine units etc. Stainless steel flexible conduit allows using sensor in harsh environment, where standard connecting cable would fail..

3.2 Description

The sensor is composed of screw coupling, suspended measuring stem and extension or compensation cable embedded in metal protective conduit. The sensor can have single or double resistance sensor Pt100 or single or double thermocouple sensor type “J” or “K”.

The sensor is to be mounted to the screw bore with diameters according to selected sensor version. Measuring stem of the sensor is suspended with suspension travel of 3.5 mm. This allows additional tolerance during making of a bore and sufficient downforce of the measuring stem to the bore bottom. All outer parts of the sensor are made of stainless steel..

3.3 Dimensional drawings

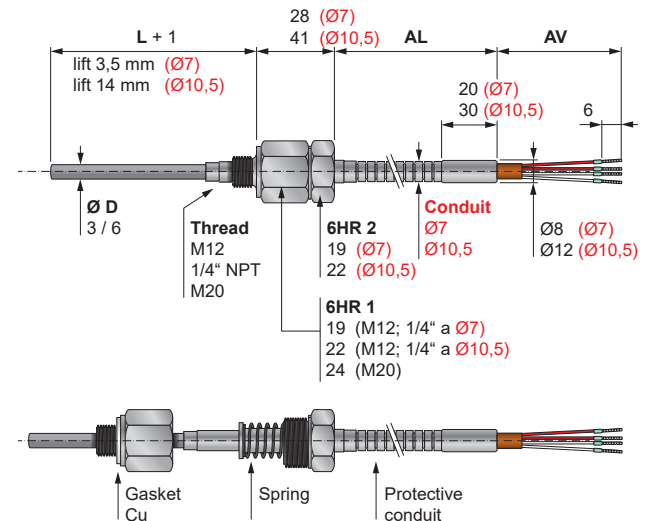

4. Installation, operation and maintenance

4.1 Installation and commissioning

4.1.1 General

Sensor is fixed to the technology by screw coupling with standard thread M12, M20x1.5 or 1/4" NPT.

4.1.2 Commissioning

Resistance temperature sensor is ready for operation after connection of connection wires between the sensor terminals and terminals of the associated apparatus and after powering on voltage supply. Thermocouple temperature sensor is ready for operation after connecting the compensation (extension) wires to the terminals of the associated apparatus (transmitter, thermostat of comparative connections, devices with internal compensation, etc.).

4.1.3 Electrical connection

RD ... red | WH ... white | BK ... black
YE ... yellow | GN ... green

Resistance sensors

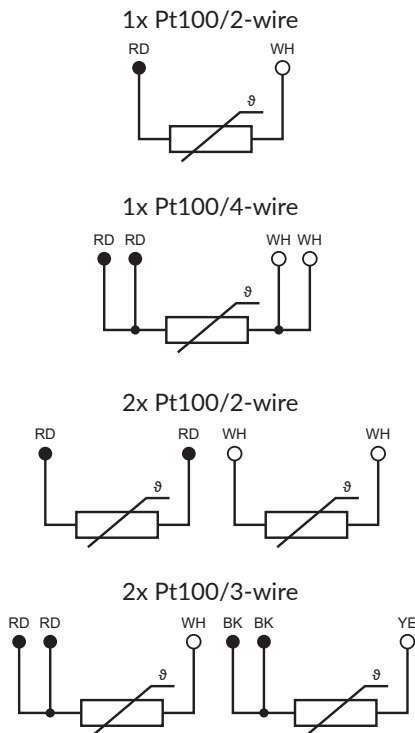

Thermocouple sensors

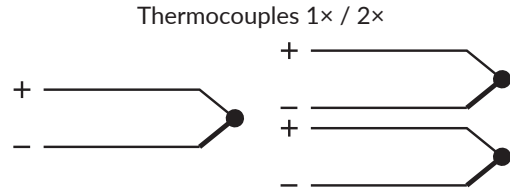

Thermocouple	Lead color (+)	Lead color (-)
"J"	BK	WH
"K"	GN	WH

4.2 Operation and maintenance

The product does not need any maintenance.

It is recommended to check the mounting of the sensor at preselected intervals.

To ensure metrological parameters of the sensors, periodic checks of calibration parameters must be performed. Period of calibrations is set by the user and it is based on operating conditions and internal metrology regulations. Manufacturer's recommended period is 12 months. If there is during the calibration found calibration difference from the expected metrological parameters, it is necessary to replace the sensor.

5. Product specifications

5.1 Technical specifications

Measuring resistor (RTD):

- 1× Pt100, 2-wire,
accuracy class B according to EN 60751
- 1× Pt100, 4-wire,
accuracy class A, B according to EN 60751
- 2× Pt100, 3-wire,
accuracy class A, B according to EN 60751
- 2× Pt100, 2-wire,
accuracy class B according to EN 60751

Thermocouple (TC):

- “J” (Fe-CuNi),
according to 1, 2 according to EN 60584-1
- “K” (NiCr-NiAl),
according to 1, 2 according to EN 60584-1

Measuring range:

- 50 to +400 °C
- 30 to +300 °C (resistance sensor, accuracy class A)

Measuring current (resistance sensor):

- recommended 0,3 to 1,0 mA
- maximal 3 mA

Dielectric strength:

- 100 Vdc (outer stem diameter 3 mm / RTD 2× 3-wire),
- 250 Vdc (outer stem diameter 3 mm / exclude RTD 2× 3-wire),
- 500 Vdc (outer stem diameter 6 mm),
- at temperature (20 ± 15) °C, max. 80 % relative humidity.

Materials:

- resistance sensor sheath
 - stainless steel 1.4401 (AISI 316)
 - stainless steel 1.4541 (AISI 321) for stem Ø 6 mm
- thermocouple sensor sheath
 - stainless steel 1.4541 (AISI 321) for thermocouple “J”
 - alloy Inconel 600 (2.4816) for thermocouple “K”
- flexible steel conduit
 - stainless steel 1.4006 (AISI 410)

Connecting and compensation wires::

- wiring diameter 0,22 mm²
- silicone isolation

Connection thread::

- M12
- M20x1,5
- 1/4" NPT

Housing (according to EN 60529):

- IP 64 (temperature sensor)
- IP 40 (flexible stainless steel conduit)

5.2 Operational conditions

Maximal temperature of screw couplings:

120 °C

5.3 Metrological parameters

Temperature sensors T1061 and T1561 can be supplied:

- as sensors with calibration,
- as sensors without calibration.

Tolerance limits of accuracy classes are listed in EN 60751 for RTD and EN 60584-1 for TC. The initial tolerance is related to the initial calibration of the sensor. Drift of the sensor meets the requirements of EN 60751, Sec. 6.5.3. To ensure accuracy of measurement, it is necessary to calibrate sensors periodically according to the operating parameters. Sensors can be supplied with calibration at several temperature points, according to customer requirements.

6. Ordering information

6.1 Ordering table

Type ① ② ③ ④ ⑤ ⑥ ⑦ ⑧ ⑨ ⑩ ⑪		
1. code	Description	
T1061	Resistance temperature sensor for plastic industry and bearings (IP64) with flexible steel conduit (IP40)	
T1561	Thermocouple temperature sensor for plastic industry and bearings (IP64) with flexible steel conduit (IP40)	

Temperature sensor ① ② ③ ④ ⑤ ⑥ ⑦ ⑧ ⑨ ⑩ ⑪		
2. code	Resistance (RTD)	Inside wiring material
04	1× Pt100, 2-wire	Cu
06	1× Pt100, 4-wire	Ni
07	2× Pt100, 3-wire	Ni
08	2× Pt100, 2-wire	Cu
only for code D105		
2. code	Thermocouple (TC)	
21	1× "J" (Fe-CuNi), insulated	
61	2× "J" (Fe-CuNi), insulated, isolated junctions	
22	1× "K" (NiCr-NiAl), insulated	
62	2× "K" (NiCr-NiAl), insulated, isolated junctions	
...U	Grounded version of junction TC	
99	Other	

Accuracy class ① ② ③ ④ ⑤ ⑥ ⑦ ⑧ ⑨ ⑩ ⑪		
3. code	Resistance (RTD) according to EN 60751	Measuring range ^{*1}
F1	B	-50 to +400 °C
F4	A	-30 to +300 °C
only for code 06 and 07		
3. code	Thermocouple (TC) according to EN 60584-1	Measuring range ^{*1}
T7	2	-50 to +400 °C
T8	1	-50 to +400 °C

^{*1} - Temperature of screw couplings constantly max. 120 °C.

Stem ① ② ③ ④ ⑤ ⑥ ⑦ ⑧ ⑨ ⑩ ⑪	
4. code	Outer diameter of stem D
S51	3 mm
S71	6 mm

Nominal length ① ② ③ ④ ⑤ ⑥ ⑦ ⑧ ⑨ ⑩ ⑪	
5. code	Immersion L
L063	63 mm
L080	80 mm
L100	100 mm
L120	120 mm
L160	160 mm
L___	other - enter custom length in mm to code

Process connection ① ② ③ ④ ⑤ ⑥ ⑦ ⑧ ⑨ ⑩ ⑪

6. code	Connecting thread Z
M12	M12 outer
M20	M20×1,5 outer
NPT1/4	1/4" NPT outer
M99	other

Protective conduit ① ② ③ ④ ⑤ ⑥ ⑦ ⑧ ⑨ ⑩ ⑪

7. code	Outer conduit diameter	Conduit material
D070	7 mm	stainless steel SS410
D105	10,5 mm	stainless steel SS410
D999	other	

Conduit length ① ② ③ ④ ⑤ ⑥ ⑦ ⑧ ⑨ ⑩ ⑪

8. code	Dimension AL
AL1000	1000 mm
AL2500	2500 mm
AL4000	4000 mm
AL6300	6300 mm
AL_____	other - enter custom length of conduit in mm to code (100 mm steps)

Free cable length ① ② ③ ④ ⑤ ⑥ ⑦ ⑧ ⑨ ⑩ ⑪

9. code	Dimension AV
+150	150 mm
+_____	other - enter custom length in mm to code

Version of cable insulation ① ② ③ ④ ⑤ ⑥ ⑦ ⑧ ⑨ ⑩ ⑪

10. code	Description
I2	Teflon
I9	other

Cable termination ① ② ③ ④ ⑤ ⑥ ⑦ ⑧ ⑨ ⑩ ⑪

11. code	Description
01	Insulated pressing tube according to DIN 46228
09	other

Optional accessories ① ② ③ ④ ⑤ ⑥ ⑦ ⑧ ⑨ ⑩ ⑪ ...

Code	Calibration in customer defined points, including certificate of calibration
KTE31A	Resistance temperature sensor calibration in 3 points in range -40 to +400 °C
KTE41A	Resistance temperature sensor calibration in 4 points in range -40 to +400 °C
KTE51A	Resistance temperature sensor calibration in 5 points in range -40 to +400 °C
KTE32AA	Thermocouple temperature sensor calibration in 3 points in range -40 to +400 °C
KTE42AA	Thermocouple temperature sensor calibration in 4 points in range -40 to +400 °C
KTE52AA	Thermocouple temperature sensor calibration in 5 points in range -40 to +400 °C
KTE9	other

Example of order:
 ① ② ③ ④ ⑤ ⑥ ⑦ ⑧ ⑨ ⑩ ⑪
 ↓
T1561 21 T7 S51 L100 M12 D070 AL2500 +150 I2 01
KTE32AA (0, 50, 100 °C)



JSP Industrial Controls

JSP, s.r.o.

Raisova 547, 506 01 Jičín

Czech Republic

+420 493 760 811

jsp@jsp.cz

www.jsp.cz

JSP Service Line

+420 605 951 061

www.jsp.cz