

MANUAL

ModuTEMP® 70

Modular Resistance and Thermocouple Temperature Sensors without/with Transmitter



- Measuring resistor 1× / 2× Pt100, thermocouple 1× / 2× "J", "K", "N", "T".
- Measuring range -200 to +700 °C (Pt100), -200 to +800 °C ("J"), -200 to +1300 °C ("K", "N").
- Accuracy class A, B according to EN 60751, 1, 2 according to EN 60584-1.
- Stem material stainless steel 1.4541, 1.4404, 2.4816, Nicrobell/Pyrosil.
- Extension piece (thermowell) material stainless steel 1.4541
- Protective tube material stainless steel 1.4541, 1.4841, 1.4845, 1.4762, Kanthal AF.
- Optional headmounted transmitter with output 4 to 20 mA, HART, Profibus, Fieldbus, including version with galvanic isolation and intrinsically safe version.
- Housing IP 65, IP 68.
- Intrinsically safe version
(Ex) II 1/2G Ex ia IIC T6...Tx°C Ga/Gb
(Ex) II 1/2D Ex ia IIIC T₂₀₀85°C...T₂₀₀X°C Da/Db.
- Flameproof enclosure
(Ex) II 1/2G Ex db IIC T6...Tx°C Ga/Gb. Protection by enclosure
(Ex) II 1/2D Ex ta/tb IIIC T90°C...Tx°C Da/Db.

Content

| | | | |
|--|-----------|---|-----------|
| 1. General instructions and information | 3 | 6. Tests, certificates, standards and marking | 23 |
| 1.1 Symbols used | 3 | 6.1 Tests and certificates | 23 |
| 1.2 Safety warnings and cautions | 3 | 6.2 Standards and directives | 23 |
| 1.3 Scope of delivery | 3 | 6.3 Marking and type tag information | 24 |
| 1.4 Description of the delivery and packing | 3 | 7. Ordering information | 25 |
| 1.5 Storage | 3 | 7.1 Ordering table of version with thermowell | 25 |
| 1.6 Installation and commissioning | 3 | 7.2 Ordering table of version into thermowell | 29 |
| 1.7 Spare parts | 3 | 7.3 Ordering table of version without thermowell | 33 |
| 1.8 Repairs | 3 | 7.4 Ordering table of version without fitting | 36 |
| 1.9 Warranty | 3 | 7.5 Ordering table of straight version | 40 |
| 2. End of service and disposal | 4 | 7.6 Ordering table of spatial version for explosive atmosphere of gasses or dusts | 44 |
| 2.1 End of service | 4 | 8. Appendix | 46 |
| 2.2 Disposal | 4 | 8.1 Declaration of conformity (standard version) | 46 |
| 3. Product description | 5 | 8.2 Declaration of conformity (explosion hazard environment version - code ED/ET) | 47 |
| 3.1 Application | 5 | 8.3 Declaration of conformity (explosion hazard environment version - code EI) | 48 |
| 3.2 Description | 6 | 8.4 Declaration of conformity (explosion hazard environment version - code ET) | 49 |
| 3.3 Dimensional drawings | 7 | | |
| 4. Installation, operation and maintenance | 12 | | |
| 4.1 Installation and commissioning | 12 | | |
| 4.2 Operation and maintenance | 17 | | |
| 5. Product specifications | 18 | | |
| 5.1 Technical specifications | 18 | | |
| 5.2 Operation conditions | 20 | | |
| 5.3 Metrological parameters | 20 | | |
| 5.4 Supplementary parameters | 20 | | |
| 5.5 Restricting conditions for application in explosion hazard environment | 21 | | |

1. General instructions and information

1.1 Symbols used



Symbol of warning; for safe use it is necessary to proceed according to the instructions



Symbol CE certifies compliance of the product with the respective government directives



This product does not belong to public waste and it is subjected to separate collection



The product meets requirements for explosion hazard environment according to the further specification

RTD

Resistance sensor

TC

Thermocouple

1.2 Safety warnings and cautions



The equipment may be installed only by a qualified personnel who are familiar with national and international laws, directives, standards and with the instructions manual. The equipment shall be supplied from a safe voltage source that meets all requirements of the standard EN 61010-1 and must be installed in compliance with national requirements and standards providing safety.

The instrument may not be used for other purposes than as specified in this instruction manual. When used with head-mounted transmitter, observe also the requirements according to transmitter manual. For elimination of a risk of injury from electric shock or fire, the maximum operational parameters of the instrument may not be exceeded.

1.3 Scope of delivery

With the product is delivered:

- Manual for installation, operation and maintenance
- Certificate of calibration (only with calibrated sensors)
- Copy of EU certificate on type examination ATEX (only sensors for explosion hazard environment)

Copper sealing rings are delivered with sensors with connecting pipe union (into thermowell J13, J16, J21P, with thermowell J23, J32, J33, J63 and without thermowell J43).

1.4 Description of the delivery and packing

The product is packaged in a protective cover and provided with an identification label with a mark of the output control. The product must not be exposed to direct rain, vibrations and shocks during transport.

1.5 Storage

The products shall be stored at temperatures from 5 °C to 35 °C and maximum relative humidity 80% in the rooms with elimination of condensation of water vapours on the products. The stored products shall not be exposed to any shocks, vibrations and effects of harmful vapours and gases.

1.6 Installation and commissioning

During installation, commissioning, operation and maintenance follow the instructions in chapter 4.

1.7 Spare parts

Any of the compact parts of the product can be also ordered as a spare part if there are not required special procedures or technological operations for the exchange. In case of exchange of the measuring sensor or transmitter, it is necessary to perform a calibration in the calibration laboratory of the manufacturer after exchange.

1.8 Repairs

Products are repaired by the manufacturer. The products for repair should be sent in a packing that guarantees damping of shocks and vibrations and protects against damage during transport.

1.9 Warranty

Products are covered by a warranty for a period of 24 months from the delivery date on the delivery note. The manufacturer guarantees technical and operational parameters of the products within scope of the applicable documentation. Warranty period is specified with individual items and begins from the day of takeover of the goods by the purchaser or delivery to the carrier. Any claims concerning to defects of the goods together can be filed in writing with the manufacturer within the warranty period and the claimed product shall be presented. The claiming party shall give identification of the product, number of the delivery note and description of the fault or defect.

The manufacturer is not responsible for any defects caused by improper storage, incorrect connection, damages caused by external effects, in particular by effects of factors with excessive values, unqualified installation, improper operation or common wearing.

2. End of service and disposal

2.1 End of service



In case that sensor with flameproof enclosure (code ED) or protection by enclosure (ET) version is under voltage, the sensor shall not be dismantled, cover of the head shall not be opened and the cable outlet shall not be released!

At the end of the sensors operation, particularly sensors in explosion proof version (code ED) or protection by enclosure (code ET), dismantling of the sensors may be carried out after their disconnection from the power supply voltage.

General

Before removing and ending of service of the sensor is at first necessary to switch the control loop to manual operation, or take other appropriate action to prevent potential harm associated with the end of sensor operation. Connected power supply is switched off, the head is opened and connecting wires of the sensor are disconnected (cut off).



Sensors that are directly in contact with the medium can be unscrewed from the welded on piece or connecting pipe union only after discharging the process medium from the technology or after other appropriate action that prevents leakage of the medium, injury of persons or other dangerous consequences.

2.2 Disposal

The products do not contain any environmentally hazardous parts. When disposing the packing and destroyed or irreparably damaged product proceed according to the local regulations.

3. Product description



ModuTEMP® 70 – Modular Resistance and Thermocouple Temperature Sensors without/with Transmitter

- Measuring resistor 1× / 2× Pt100, thermocouple 1× / 2× “J”, “K”, “N”, “T”.
- Measuring range -200 to +700 °C (Pt100), -200 to +800 °C (“J”), -200 to +1300 °C (“K”, “N”).
- Accuracy class A, B according to EN 60751, 1, 2 according to EN 60584-1.
- Stem material stainless steel 1.4541, 1.4404, 2.4816, Nicrobell/Pyrosil.
- Extension piece (thermowell) material stainless steel 1.4541
- Protective tube material stainless steel 1.4541, 1.4841, 1.4845, 1.4762, Kanthal AF.
- Optional headmounted transmitter with output 4 to 20 mA, HART, Profibus, Fieldbus, including version with galvanic isolation and intrinsically safe version.
- Housing IP 65, IP 68.
- Intrinsically safe version
(Ex) II 1/2G Ex ia IIC T6...Tx°C Ga/Gb
(Ex) II 1/2D Ex ia IIIC T₂₀₀85°C...T₂₀₀X°C Da/Db.
- Flameproof enclosure
(Ex) II 1/2G Ex db IIC T6...Tx°C Ga/Gb.
- Protection by enclosure
(Ex) II 1/2D Ex ta/tb IIIC T90°C...Tx°C Da/Db.

3.1 Application

Industrial resistance (RTD) and thermocouple (TC) temperature sensors ModuTEMP® 70 made on the basis of interchangeable measuring inserts with mineral insulation are designed for accurate remote temperature measuring and temperature control of liquid and gaseous mediums in non-hazardous or in hazardous locations with potentially explosive atmosphere of gases or dusts (ATEX certificate).

Sensors can be supplied with connecting terminal box or with transmitter with output from 4 to 20 mA, possibly HART, Fieldbus, Profibus mounted in the sensor head.

J23, J32, J33, J63 – Sensors with thermowell

Sensors are intended for temperature measurement of flowing fluids, gasses and powdery mediums in pipelines, tanks, etc., at low to medium pressures and flowing velocities of a medium.

Thermowell is in this case an integral part of the sensor.

Submersible part of the sensor (thermowell) or possibly adjacent part for sealing (at sensor with a flange) can be coated by special plastic paint (Halar, Hyflon, polyamide, etc.) to increase corrosion resistance. Increasing resistance of thermowell against abrasion and erosion can be provided by coating with resistant corundum or other layer.

J13, J16, J21P – Sensors into thermowell

The sensors into the thermowell must be assembled with appropriate cylindrical or conical thermowell. Using this sensors without thermowell is not recommended and for flameproof enclosure (code ED) and protection by enclosure (code ET) version is prohibited.

The sensors in combination with suitable thermowell are intended for temperature measurement of flowing fluids, gasses and powdery mediums in pipelines, tanks, etc., at middle to high pressures (PN 250, PN 400) and flowing velocities of mediums (90 m/s).

Measuring insert RTD is efficient up to 700 °C, measuring insert TC “J” up to 800 °C and “K”, “N” up to 1300 °C, although measuring range of complete sensor is given by temperature resistance of used thermowell. The massive high-proof thermowells made of special materials extend the time of the sensor reaction. The strengths of these sensors are in easy operating service without breach of pressure technology tightness.

J43 – Sensors without thermowell

These sensors do not have protective thermowell and the sheath of measuring insert is directly in contact with the medium. The measuring insert is inseparably connected (welded, soldered) with a sensor fitting. Sensors are intended for measurement with higher requirements on quick reaction time of temperature change. They are used for lower pressures and lower velocities of medium.

B00, B01 – Sensors without fitting

Sensors are intended for temperature measurement of flowing and non-flowing fluids, gasses and powdery mediums at relative low pressures and flowing velocities of medium, at higher requirements on short reaction time of temperature change.

The required immersion is adjustable by fixing shift pipe union.

The stem length of sensor is not limited. Sensors with a length over one meter are supplied as default with measuring stem coiled into a circle.

The sensor can be used also for measurement of surface temperature and temperature in hard accessible places, where is used of advantage of workable stem with minimal curve diameter 5D, where D is diameter of the sensor stem.

B53, B63, B64, B66, B73, B74, B83, B84, B85, B86, B84Z, B842, B843, B852, B853 – Straight sensors

Straight sensors are intended for temperature measurement of liquid, gaseous and powdery mediums in furnaces, incinerators with overpressure up to 100 kPa.

Increasing resistance against abrasion and erosion can be provided by coating with resistant corundum or other layer.

P1E – Spatial sensors for explosive atmosphere of gasses or dusts

Spatial sensors are intended for ambient temperature measurement in locations of their installation.

3.2 Description

Modular concept, variable dimension and used materials simplify ordering and application of modular temperature sensor ModuTEMP® 70.

Main part of the sensor is exchangeable measuring insert assembled with head and in some versions with protective fitting of the sensor.

Exchangeable measuring insert is fastened in sensor head by two suspended screws, providing down-force on thermowell bottom (or protective tube).

RTD - Resistance sensor is made of one or two measuring resistors, embedded in the stem of exchangeable measuring insert. Resistors are connected by inner wiring to the terminal block in the sensor head. There is used defined resistance change according to temperature change. At sensors with transmitter is resistance signal further transformed to linearized unified current signal 4 to 20 mA, optionally to HART, Profibus, Fieldbus output.

TC - Thermocouple sensor is made of one or two thermocouples, embedded in the stem of exchangeable measuring insert and connected to terminal block in the sensor head. There is used the defined change of thermoelectric voltage according to the temperature change. At sensors with transmitter is output thermocouple signal further transformed to linearized unified current signal 4 to 20 mA, optionally to HART, Profibus, Fieldbus output.

3.3 Dimensional drawings

Resistance and thermocouple measuring inserts with mineral isolation

Cold-end

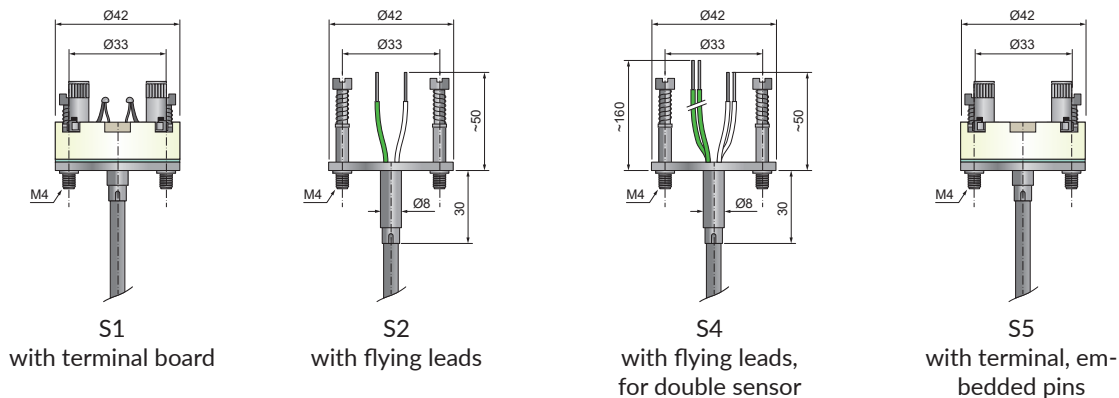

Measuring-end

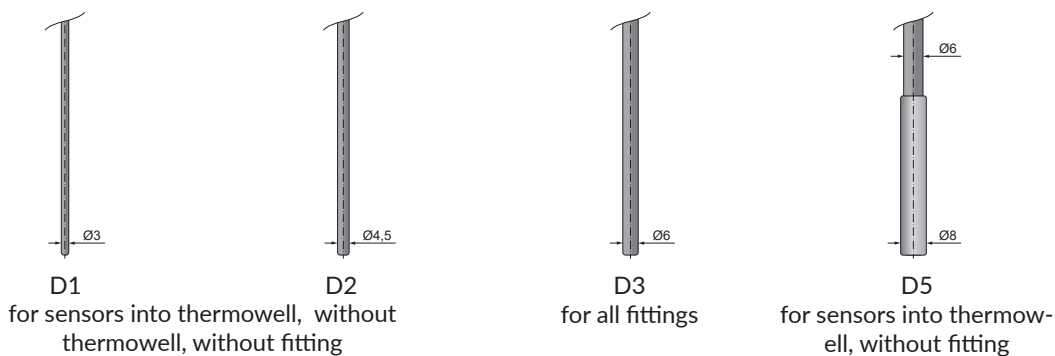

Head

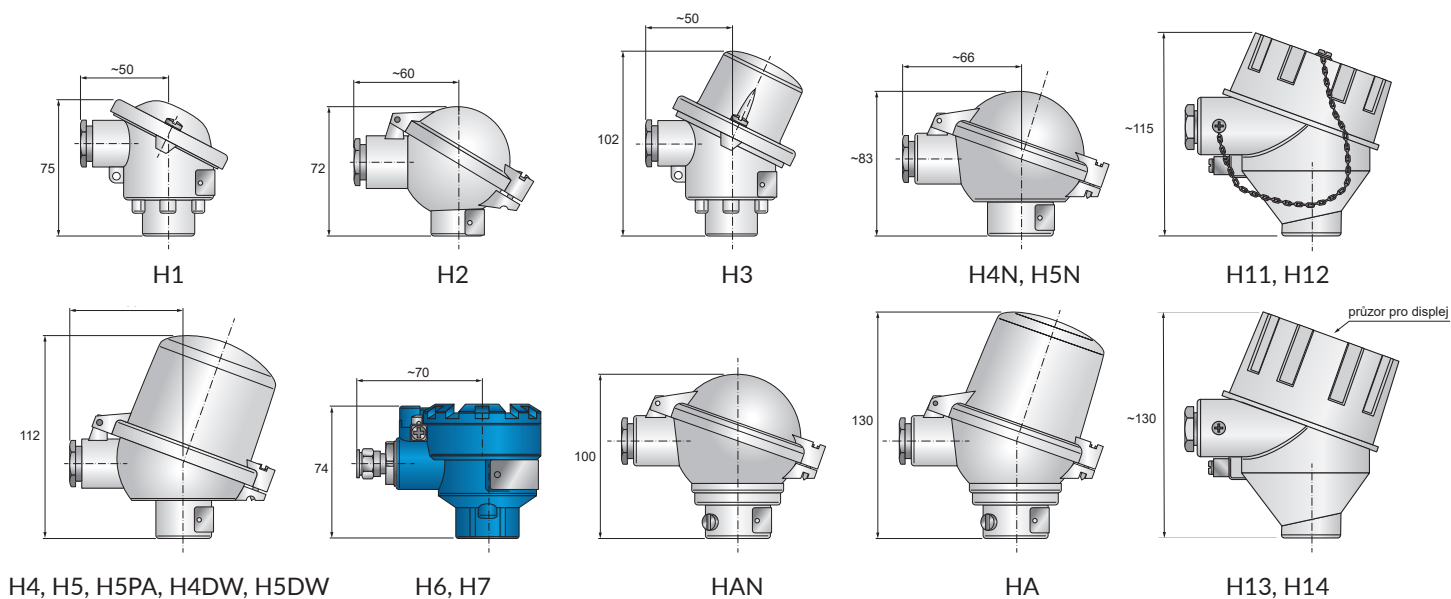

Fittings

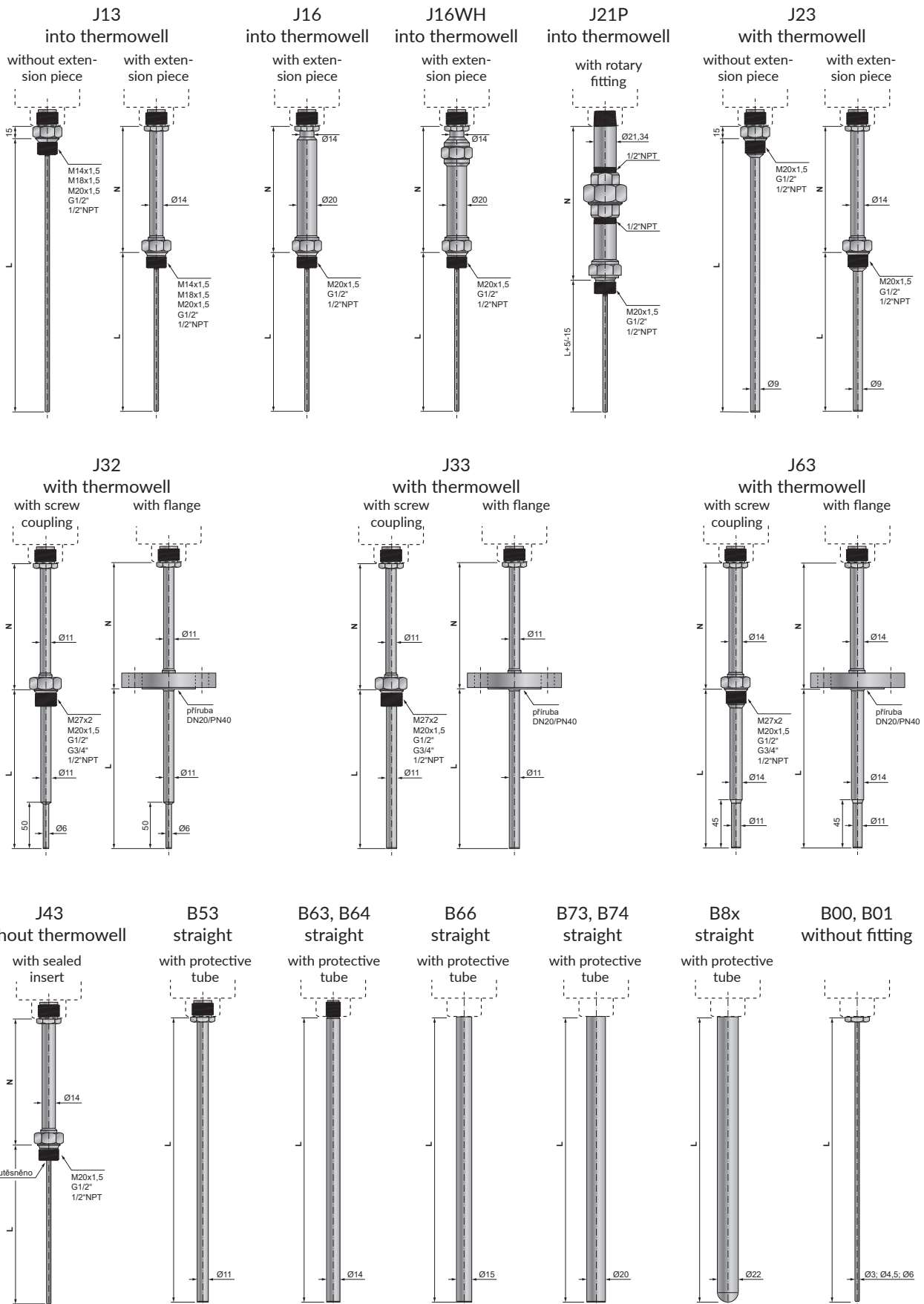

Thermowells

WT70 C, for screwing

WT70 C 01 V900 ...

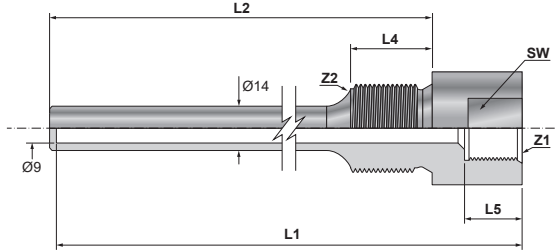

WT70 C 01 V700 ...

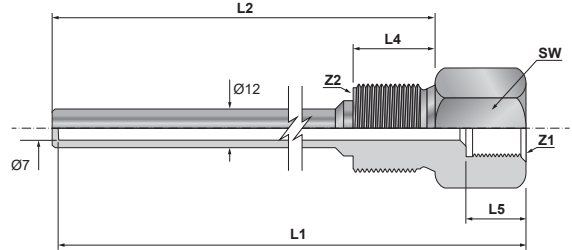

WT70 C 01 V900 ...

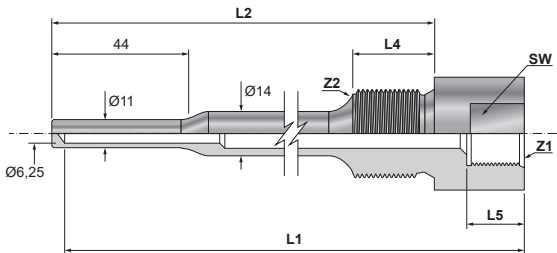

WT70 C 01 V350 / V500 ...

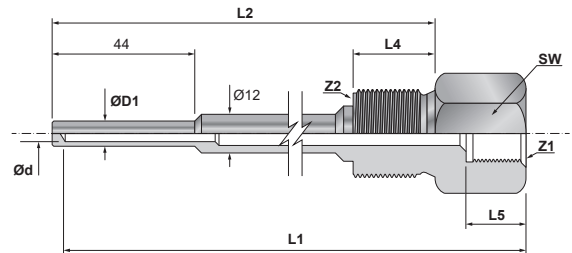

WT70 C, for welding

WT70 C 02 V900 ...

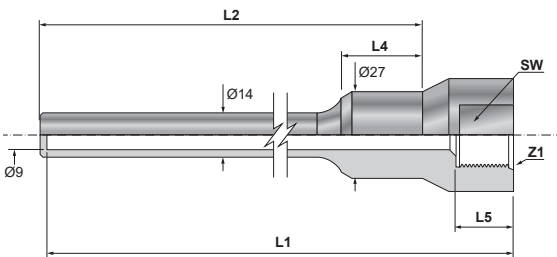

WT70 C 02 V700 ...

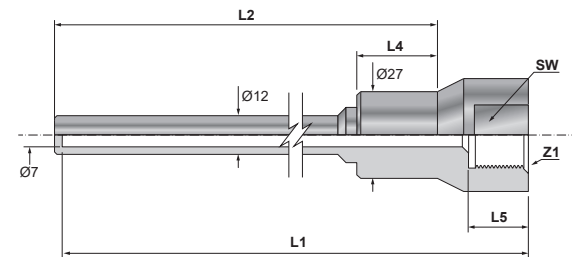

WT70 C 02 V625 ...

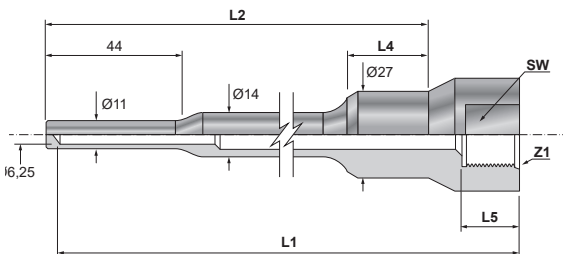

WT70 C 02 V350 / V500 ...

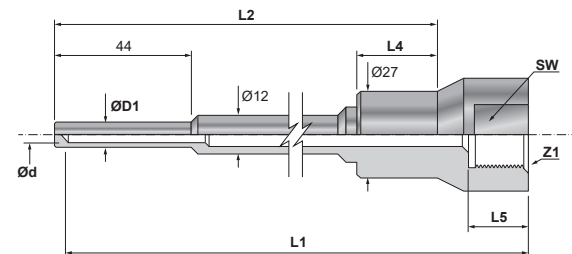

WT70 C, with flange

WT70 C 03 V900 ...

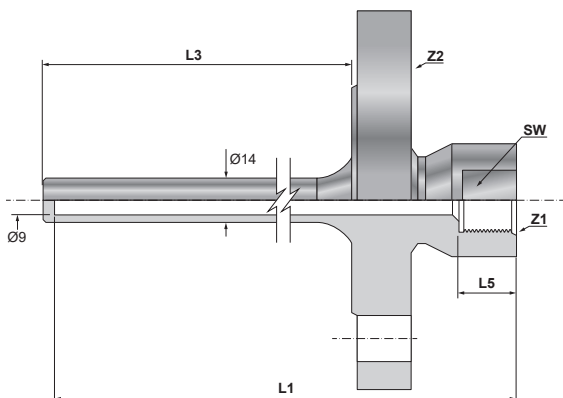

WT70 C 03 V700 ...

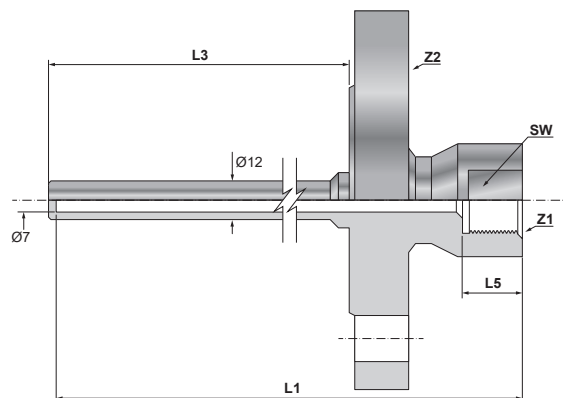

WT70 C 03 V625 ...

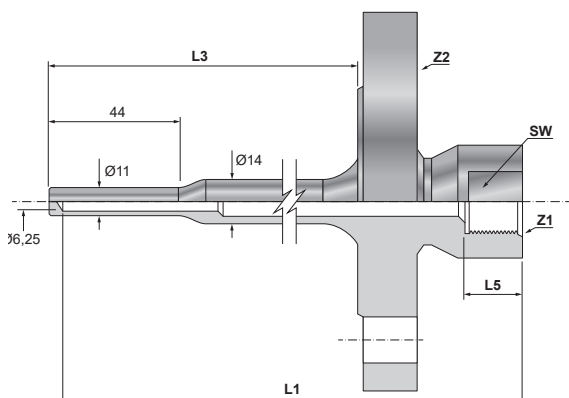

WT70 C 03 V300 / V500 ...

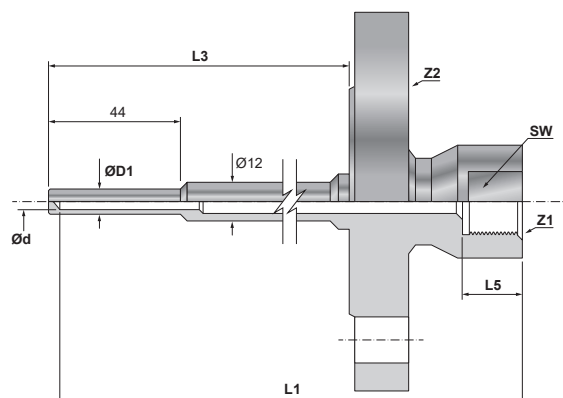

WT70 C, between flanges

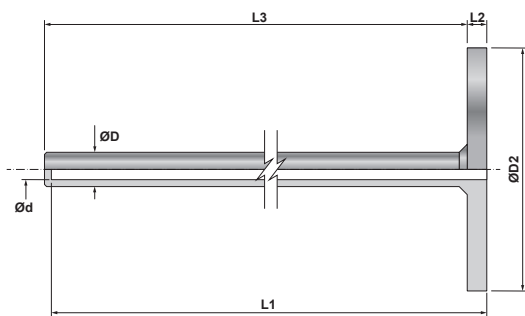

WT70 T, for screwing

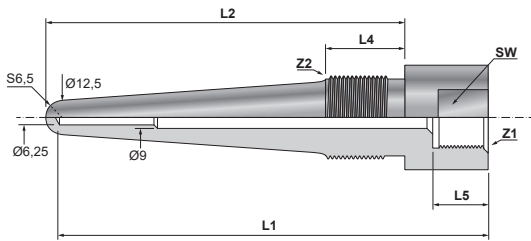
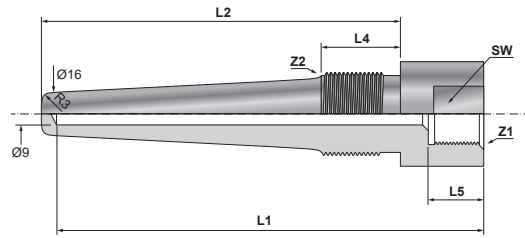
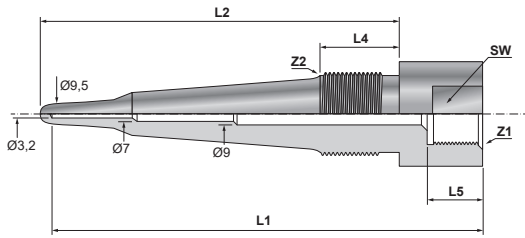

WT70 D, for welding

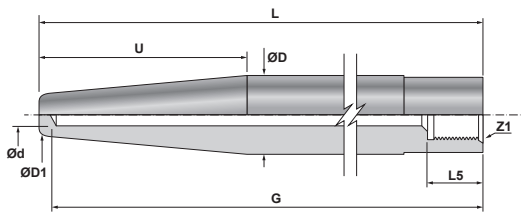

WT70 D, with flange

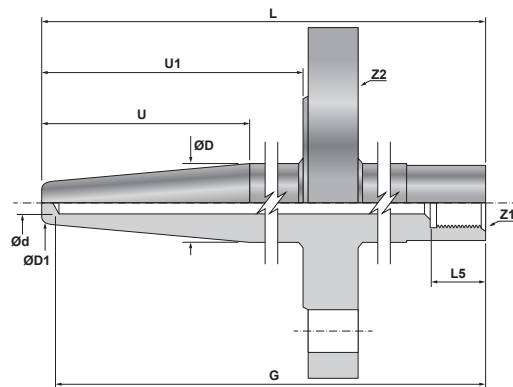

NV Welded on piece for WT70 C and WT70 T

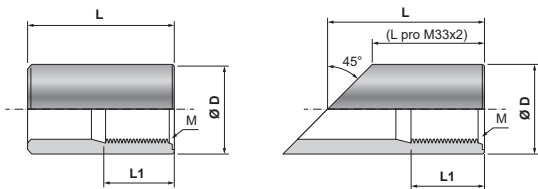

NV D Welded on piece for WT70 D

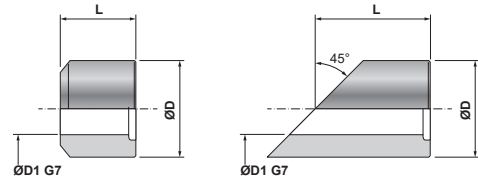

NT70 Extension piece for temperature sensors

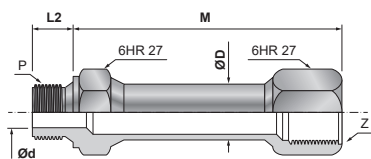

4. Installation, operation and maintenance

4.1 Installation and commissioning

4.1.1 General

Improper depth of sensor immersion to measured medium can cause a measurement deviation because the heat is diverted through a sensor stem and its process connection. To prevent this fault the recommended depth of immersion is 8 to 10 times diameter of thermowell measuring end for liquids and 10 to 15 times diameter of thermowell measuring end for gases.

In case of necessity to mount sensor into pipes of small diameter, it is recommended to mount sensor sideways or into a bend, with thermowell measuring end pointed towards the direction of medium flow. The sensors may be installed in any position with cable outlets facing down if possible. Vertical position with head up is considered as typical position.



When both connections of threaded parts are made of stainless steel, there is danger of galling (formation of cold weld). This can also occur during ordinary screwing by hand without using tightening key. If the cold weld is made, the thread is then damaged and parts are unusable. Before first screwing, it is therefore necessary to check whether threads are free of impurities (and clean if needed) and then treat the threads against galling (formation of cold weld) by appropriate lubricant. For example use paste G-Rapid plus or Lukosan M11 (in case of connection for oxygen). For tapered threads is usually used Teflon tape.

Sensor with thermowell (codes J23, J32, J33, J63) is fixed by screwing into the straight thread or oblique welded on piece on the wall of the piping, technological equipment, etc.

Sensor with flanged thermowell is fixed by screwing the mounting flange of the thermowell to the counter-flange that is welded on the wall of the piping, technological equipment, etc.

Sensor into thermowell (codes J13, J16, J21P) shall be installed into the protective thermowell installed in technological equipment. It is fixed by screwing into the inner thread of the thermowell. Construction and material of the thermowell shall sufficiently protect the measuring stem of the sensor against undesired effects of the measured medium (abrasion, erosion, chemical corrosiveness, etc.).

Sensor without thermowell (code J43) is fixed by screwing into the thread of the welded on piece on the wall of piping, technological equipment, etc.

Sensor without fitting (code B00) is fixed to the technology by fixing shift pipe union or just by insertion to the technology.

Sensor without fitting (code B01) is fixed on wall by auxiliary head holder. Stem of the sensor is fixed by fixing shift pipe union into welded on piece on the wall of the piping, technological equipment, etc. Using without fixing shift pipe union is not excluded.

Straight sensor (codes B53, B63, B64, B66, B73, B74, B83, B84, B85, B86, B84Z, B842, B843, B852, B853) is fixed to the

technology by fixing shift flange or by fixing shift pipe union.

Spatial sensor (code P1E) is fixed on wall or construction by auxiliary head holder.

Connection of wires

Resistance sensor without installed transmitter is connected to the decoding devices using copper connection cable wires with cross section 0.5 to 1.5 mm².

Thermocouple sensor without installed transmitter is connected to the decoding devices using extension or compensation cable wires with cross section 0.22 to 1.5 mm².

Connection terminal is accessible after removal of the head cover. Drawing of the connection terminals and wiring are shown on the scheme of electrical connection. The sensor outlet shall be carefully sealed after connection of the wires.

Notes:



Pay proper attention to find suitable position of the sensor cable outlet.

The head of all sensors with fitting without extension piece (codes J13, J16, J21P, J23 with N000) shall not be turned against the connecting pipe union.

The head of all sensors with fitting with extension piece can be turned after loosening the fitting nut (under the head) to desired position of the sensor cable outlet.

For sensors into the thermowell (codes J13, J16, J21P), because of tight or curved bore of the inner thermowell bore, it is not possible to freely rotate with measuring insert in thermowell. Thus before the installation of the sensor, it is needed to dismount the measuring insert from the sensor's fitting, install fitting into the thermowell, turn the head with cable outlet to desired position and only then install measuring insert back into the fitting of the sensor.

During installation of sensors without thermowell (code J43) there shall not be turned by head against extension piece of more than one turn to prevent distortion of the internal wiring.

For sensors without fitting (codes B00, B01), there shall not be turned by head against the stem of measuring insert.

For straight sensors (codes B63, B64, B66, B73, B74, B83, B84, B85, B86, B84Z, B842, B843, B852, B852) there shall not be turned by head against protection tube.

4.1.2 Commissioning

Resistance temperature sensor without transmitter in the head is ready for operation after connection of copper connection wires between the sensor terminals and terminals of the associated apparatus and after mounting head cover.

Resistance temperature sensor with transmitter in the head (installed in the head cover) is ready for operation if terminals of the measuring insert and transmitter are connected by the

attached connection wires and after connection of copper connection wires between the transmitter terminals and terminals of the associated apparatus and after mounting head cover.

Resistance temperature sensor with transmitter in the head (installed on the measuring insert flange instead of a ceramic terminal strip) is ready for operation after connection of copper connection wires between the transmitter terminals and terminals of the associated apparatus and after mounting head cover.

Thermocouple temperature sensor without transmitter in the head is ready for operation after connection of compensation (extension) wires between the sensor terminals and terminals of the associated apparatus (transmitter, thermostat of comparator connections, devices with internal compensation, etc.) and after mounting head cover.

Thermocouple temperature sensor with transmitter in the head (installed in the head cover) is ready for operation if terminals of the measuring insert and transmitter are connected by the attached compensation (extension) wires and after connection of copper connection wires between the transmitter terminals and terminals of the associated apparatus and after mounting head cover.

Thermocouple temperature sensor with transmitter in the head (installed on the measuring insert flange instead of a ceramic terminal) is ready for operation after connection of copper connection wires between the transmitter terminals and terminals of the associated apparatus and after mounting head cover.

ATTENTION! Sensor with flameproof enclosure (code ED) and protection by enclosure (code ET) may be put into operation after tightening the cover of the head and cable glands.

4.1.3. Installation of the sensors into explosion hazard environment acc. to EN 60079-0, EN 60079-1, EN 60079-10 and EN 60079-31

Sensor versions:

- code ED: Flameproof enclosure Ex d
- code ET: Protection by enclosure Ex t
- code EI: Intrinsically safe version Ex i

Special conditions for safe use of sensors in ED, ET, EI version



Any intervention into construction of the sensor with a ED, ET or EI version is not permitted and may cause an explosion!

The sensors for explosion hazard environment shall be used only in the environment and mediums that their properties (abrasion, chemical corrosiveness, vibrations, etc.) do not damage fitting of the sensor.

In addition to specified cable glands, it is possible to use for the sensors also other cable glands with connection thread M20x1.5 and with individual approval for specific type of protection. Cable gland must meet the requirements of EN 60079-1.

When using cable glands (code KME1, KME2) designed for fixed cable installation, the cable shall be fixed against a possible rotation and displacements. Cable gland provides proper protection if it is correctly tight and used with sealing.

Used cable must have a circular cross section and eventually it

is not allowed to banding it to change its diameter.

User is obliged to ensure installation of temperature sensor in ED, ET, EI version in such a way, that there is no influence of external heat sources (measured medium, sun heating, etc.) on the surface of the sensor and its fittings that could lead to exceeding defined maximum surface temperature.

Special conditions for safe use of sensors with flameproof enclosure (code ED)

Sensor with flameproof enclosure (code ED) shall be installed in such way, that the distance between flameproof enclosure (threaded gap of head cover) and ambient walls, constructions or other solid barriers is at least 40 mm. The head cover (H6, H7) must be tightened, that dimension of gap between the head cover and head body is maximally 0,2 mm! The ambient temperature of the head must be within the range specified in section 5.2 - Operating conditions. The temperature in the head may be increased by transferring heat from the process. Therefore to prevent overheating of head parts, it must be ensured corresponding minimum length of uninsulated extension piece of sensor or protection tube. Minimum length of uninsulated extension piece or protective tube depending on the process temperature and the ambient temperature shall be determined for tube of extension piece with diameter 11 to 14 mm according to Graph No. 1 and for tube of extension piece with diameter 20 mm according to Graph No. 2.

Special conditions for safe use of sensors in intrinsically safe version (code EI)

Temperature sensors in intrinsically safe version (code EI) can be connected to intrinsically safe circuits of electrical equipment Group II . Temperature sensor without transmitter does not have any own ignition source. All potential sources of ignition are brought from environment (electric energy causing warming and thermal energy from a technological connection) and their size and safety (danger) must be assessed by the user during installation. Input parameters of the sensor without the transmitter are $U_i = 30 \text{ V}$, $I_i = 30 \text{ mA}$, $P_i = 0.1 \text{ W}$. Sensor with length 1 m has a maximum internal parameters $C_i = 1 \text{ nF}$ and $L_i = 0,020 \text{ mH}$, In case of longer sensor, these values should be multiplied by the length of the sensor. Input parameters of the sensor with transmitter/display installed in the sensor head are given by parameters of used transmitter/display.

When connecting the sensor into the intrinsically safe circuit, these circuits must be considered to be electrically connected to earth potential through the grounded sheath of the sensor. The user must eliminate other connection of intrinsically safe circuit to earth potential using associated apparatus (transmitter, Ex barriers) galvanic isolated from the other circuits. Associated apparatus shall meet the requirements of EN 60079-11. During installation is also necessary to respect the requirements of EN 60079-14, EN 60079-25 and other relevant standards.

Heads with code H5, H5N, H6 and H7 have inner and outer ground terminal for grounding or interconnection and thus meet the requirements of standard EN 60079-0, article 15.1 and 15.2.

Measurement part of the sensor has surface temperature equal to the temperature of the process fluids and therefore it is crucial for determining the temperature class (for T6 to T1) or the maximum surface temperature T_x .

The surface temperature of sensor head depends on the sensor type, method of installation, process temperature, ambient temperature and power loss of used transmitter. Temperature class of temperature sensor head with mounted transmitter/display with max power $P_{\text{max}} = 1 \text{ W}$ is T4 according to EN 60079-0 with ambient temperature up to 80 °C. Used transmitter/display and associated apparatus must have a type certificate in accordance with the relevant standards and regulations. Final intrinsically safe circuit has to be assessed according to EN 60079-25. If further warming of head due to heat transfer of technology can occur, it is necessary to determine the temperature class based on information from manual or based on measuring surface temperature according to relevant standards.

Temperature of other sensor surfaces that are in contact with explosive atmospheres must be determined individually after on-site installation and must not exceed the ignition temperature of the explosive gas atmosphere and/or exceed 2/3 of T_{cl} - ignition temperature of scattered dust.

If the measuring end of sensor in version EI is installed in Zone 0, 1, 20 or 21, and if electric power P_0 of intrinsically safe transmitter passed into the sensor is higher than 0.05 W, the increase of temperature of the measuring end in the case of failure of the transmitter can exceed 10 °C. In this case, it is necessary to determine real increase of temperature of measuring end under these conditions and to assess the ignition risk of explosion. When installed in Zone 2, transmitter failure is not considered and is sufficient if the power passed into the sensor does not exceed 0.05 W. Information about maximum power passed into the sensor can be found in the operating manual of the transmitter or associated apparatus.

J13, J16, J21P - Sensor into thermowell in ED, ET, EI version

Sensor into thermowell can be placed in, Zone 1, 2, 21, 22. Sensor must be mounted into the protective thermowell. Wall thickness of the thermowell must be at least 1 mm. Material of

the thermowell must resist in the long term influence of medium and ambient environment. Protective thermowell can be installed in Zone 0, 1, 2, 20, 21, 22 according to EN 60079-10.

J23, J32, J33, J63 - Sensor with thermowell in ED, ET, EI version

Submersible part of the sensor (thermowell) can be mounted in Zone 0, 1, 2, 20, 21, 22 according to EN 60079-10. Other parts of the sensor (head, extension piece) can be placed in Zone 1, 2, 21, 22.

B53, B63, B64, B66, B73, B74, B83, B84, B85, B86, B84Z, B842, B843, B852, B853 - Straight sensor in ED, ET, EI version

Submersible part of the sensor (protective tube) can be placed in Zone 0, 1, 2, 20, 21, 22 according to EN 60079-10. Head of the sensor can be placed in Zone 1, 2, 21, 22.

P1E - Spatial sensors in ED, ET, EI version

Sensor can be mounted in Zone 1, 2, 21, 22 according to EN 60079-10. Head of the sensor can be placed in Zone 1, 2, 21, 22.

J43 - Sensor without thermowell in EI version

Submersible parts of the sensor (stems of measuring inserts) can be placed in, Zone 0, 1, 2, 20, 21, 22 according to EN 60079-10. Other parts of the sensor (head, extension piece) can be placed in Zone 1, 2, 21, 22.

B00, B01 - Sensor without fitting in EI version

Submersible part of the sensor (stem of measuring insert) can be placed in, Zone 0, 1, 2, 20, 21, 22 according to EN 60079-10. Head of the sensor can be placed in Zone 1, 2, 21, 22.

Graph No. 1

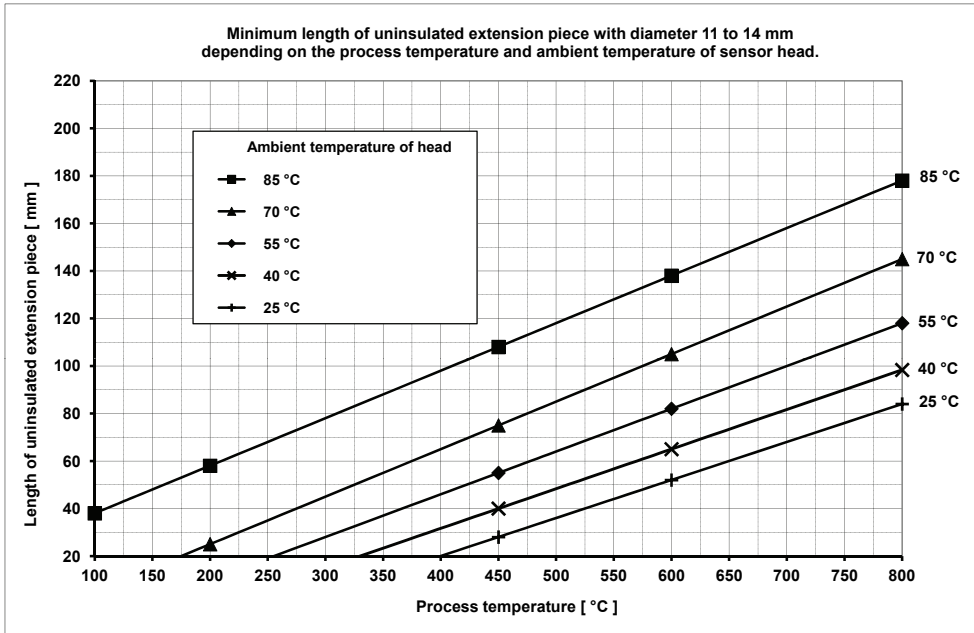

Graph No. 2

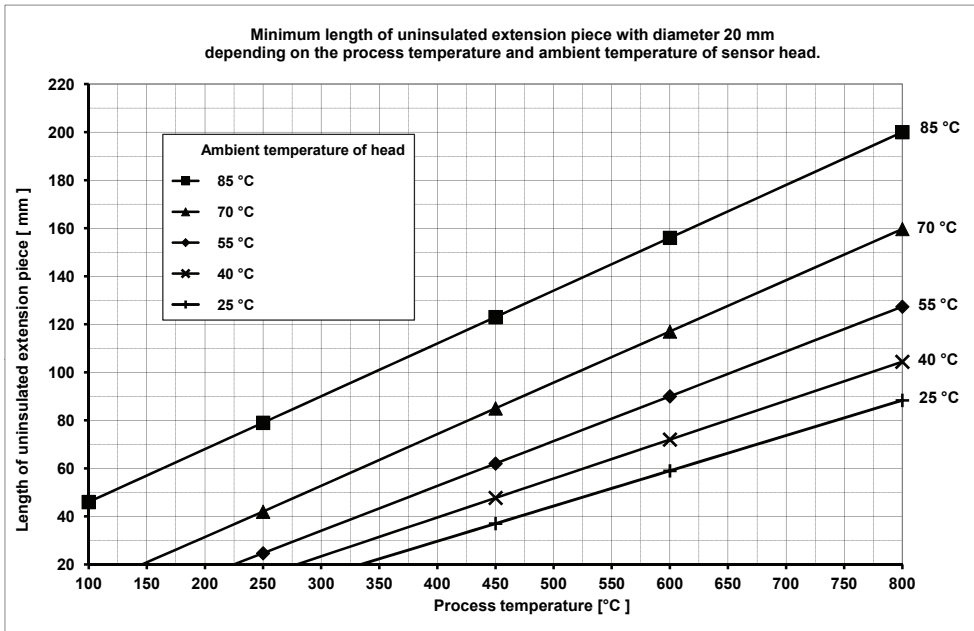

4.1.4 Electrical connection

RTD

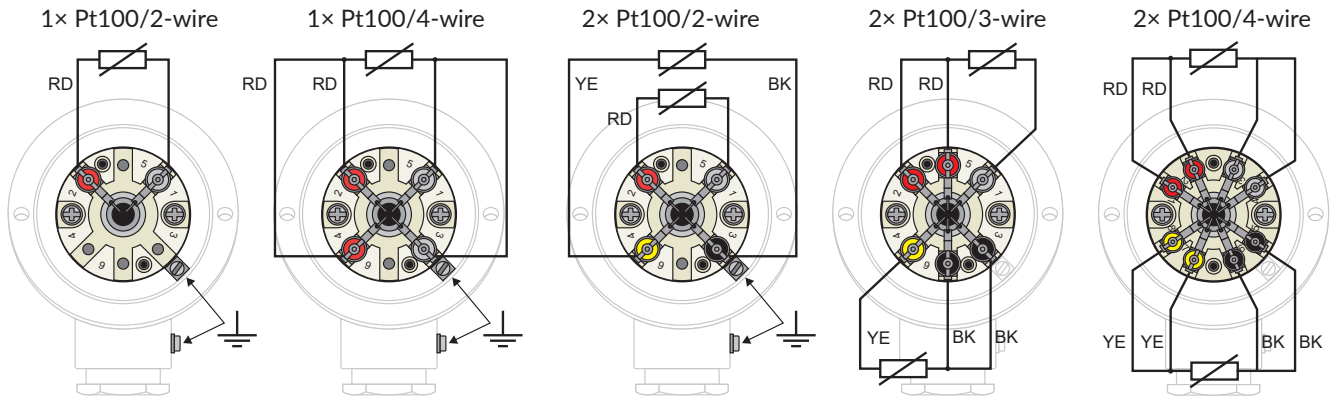

TC

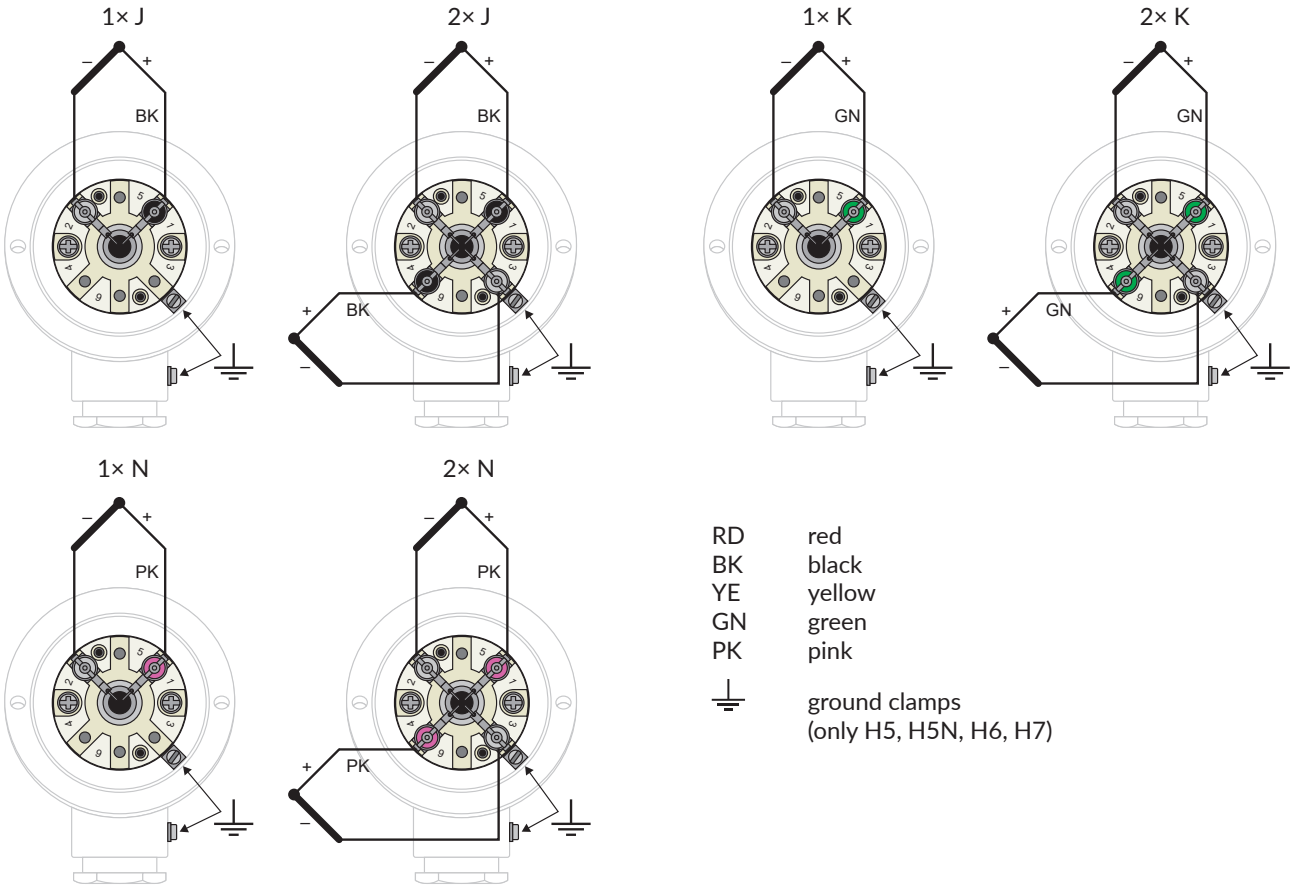

4.1.6 Examples of mounting of the sensors in operation

Sensors with thermowell

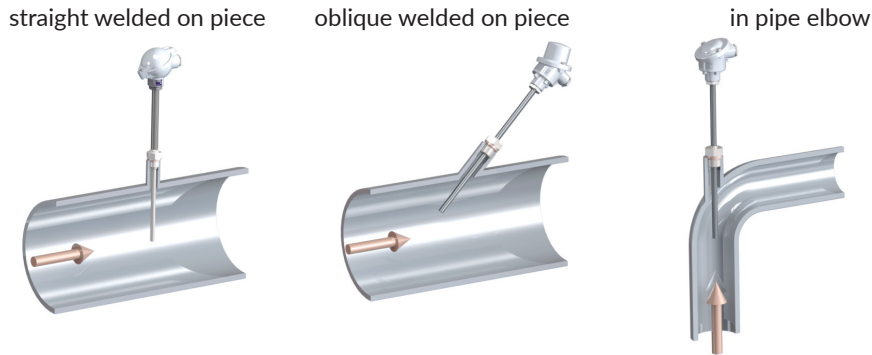

Sensors into thermowell

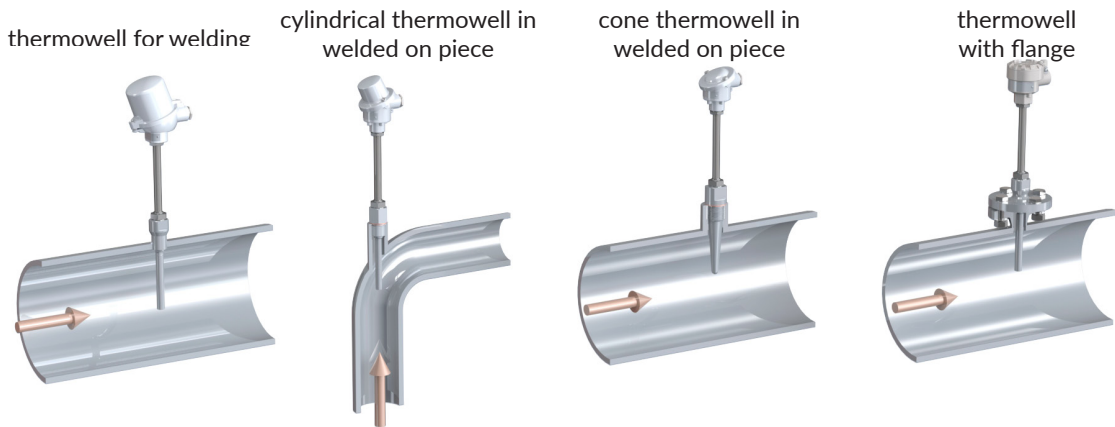

Straight sensors (without fitting)

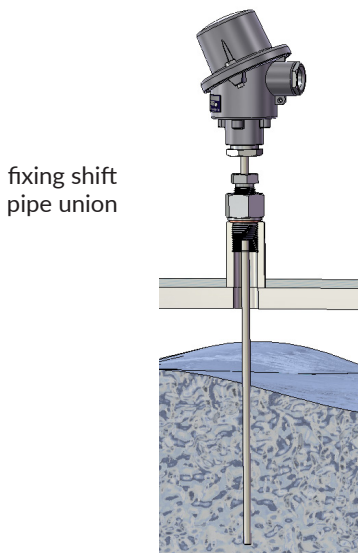

4.2 Operation and maintenance

The product does not need any operation or maintenance.

It is recommended to check the mounting of the sensor at preselected intervals.

To ensure metrological parameters of the sensors, periodic checks of calibration parameters must be performed. Period of calibrations is set by the user and it is based on operating conditions and internal metrology regulations. Manufacturer's recommended period is 12 months. If there is during the calibration found difference from the expected metrological parameters, it is necessary to replace the measuring insert.



In case that the sensor with flameproof enclosure (code ED) or protection by enclosure (code ET) version is under voltage, the sensor shall not be dismantled, cover of the head shall not be opened and the cable outlet shall not be released! Any intervention into construction of the sensor with a explosion proof version is not permitted and may cause an explosion!

5. Product specifications

5.1 Technical specifications

Resistance sensors type T1070

Measuring resistor:

1× Pt100, accuracy class A, B according to EN 60751
 inside wiring: two-wire, four-wire
 2× Pt100, accuracy class A, B according to EN 60751,
 inside wiring: two-wire, three-wire

Measuring range:

-200 to +700 °C

Measuring current:

recommended ≤ 1 mA
 maximal 2 mA

Output signal:

without transmitter resistance
 with transmitter linearized 4 to 20 mA,
 other after agreement

Dielectric strength:

500 V eff
 250 V eff (only for version with outer sheath diameter
 3 mm, 1× Pt100/4-wire connection, 2× Pt100/3-wire
 connection) at temperature (20 ±15)°C, max. 80 % relative
 humidity

Electrical insulation resistance:

min. 100 MΩ according to EN 60751,
 at temperature (25 ±10)°C, max. 80 % relative humidity

Thermocouple sensors type T1570

Thermocouple:

1× / 2× "J", "K", "N",
 accuracy class 1, 2 according to IEC 584-2

Measuring range:

-200 to +800 °C ("J")
 -200 to +1300 °C ("K", "N")

Output signal:

without transmitter voltage
 with transmitter linearized 4 to 20 mA

Dielectric strength:

500 V eff (including version "1×J", "1×K", "1×N" with outer
 sheath diameter 3 mm)
 250 V eff (only for version "2×J", "2×K", "2×N" with outer
 sheath diameter 3 mm)
 at temperature (20 ±15)°C, max. 80 % relative humidity

Electrical insulation resistance:

min. 1000 MΩ according to EN 61515,
 at temperature (20 ±15)°C, max. 80 % relative humidity

Standard version of measuring junction:

single insulated / double insulated separated

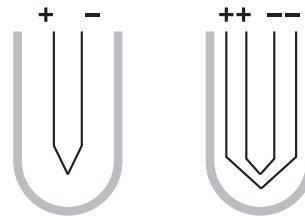

General

Response time for resistance sensors type T1070:

Version J43, B00, B01

| Stem diameter [mm] | t0,5 [s] | | t0,9 [s] | |
|-------------------------------|----------|-----|----------|-----|
| | water | air | water | air |
| 3 | 1,5 | 14 | 4 | 41 |
| 4,5 | 3 | 23 | 9 | 71 |
| 6 | 4 | 38 | 13 | 118 |
| 6 with distance sleeve Ø 8 | 9,5 | 89 | 28 | 280 |

Version J23 (thermowell 9×1)

| Stem diameter [mm] | t0,5 [s] | | t0,9 [s] | |
|-----------------------|----------|-----|----------|-----|
| | water | air | water | air |
| 6 | 25 | 114 | 75 | 356 |

Version J33 (thermowell 11×2)

| Stem diameter [mm] | t0,5 [s] | | t0,9 [s] | |
|-----------------------|----------|-----|----------|-----|
| | water | air | water | air |
| 6 | 32 | 170 | 96 | 534 |

Response time for thermoelectric sensors type T1570:

Version J43, B00, B01

| Stem diameter [mm] | t0,5 [s] | | t0,9 [s] | |
|-----------------------|----------|-----|----------|-----|
| | water | air | water | air |
| 3 | 1 | 22 | 3 | 64 |
| 4,5 | 2,5 | 34 | 6,5 | 113 |
| 6 | 3 | 55 | 9 | 170 |

Version J23 (thermowell 9×1)

| Stem diameter [mm] | t0,5 [s] | | t0,9 [s] | |
|-----------------------|----------|-----|----------|-----|
| | water | air | water | air |
| 6 | 9 | 165 | 27 | 510 |

Version J33 (thermowell 11x2)

| Stem diameter [mm] | t0,5 [s] | | t0,9 [s] | |
|-----------------------|----------|-----|----------|-----|
| | water | air | water | air |
| 6 | 14 | 248 | 41 | 765 |

$v_{WATER} = 0,4 \text{ m/s}$, $v_{AIR} = 2 \text{ m/s}$,

t0,5 ... 50 % of temperature step

t0,9 ... 90 % of temperature step

Materials:

head

- aluminium alloy (codes H1, H2, H3, H4(N), H5(N), H6)
- stainless steel 1.4541 (17248, AISI 321), (code H7)
- polyamide (code H5PA)

stem of measuring insert

- Pt100 - stainless steel 1.4404 (17349, AISI 316L)
- "J" - stainless steel 1.4541 (17248, AISI 321)
- "K", "N" - alloy Inconel 600, Nicrobell/Pyrosil

inside wiring

- RTD - Cu, Ni

extension piece

- stainless steel 1.4541 (17248, AISI 321), (code J13, J16, J21P, J23, J32, J33, J43, J63)

thermowells

- stainless steel 1.4541 (17248, AISI 321), (codes J23, J32, J32, J63)

protective tube

- stainless steel 1.4541 (17248, AISI 321), (codes B53, B63, B73, B83)
- heat-resisting steel 1.4845 (17255, AISI 310) (codes B64, B74, B84, B84Z, B842, B843)
- heat-resisting steel 1.4762 (17153, AISI 446) (codes B85, B852, B853)
- Kanthal AF (codes B66, B86)

Housing (according to EN 60529):

IP 65, IP 68 (according to used head)

Weight:

see table below

Weight of sensors T1070 and T1570 without transmitter with head H1 [kg]

| Sensor version / Nominal Length | J13 | J23 | J33 | | J43 | B00, B01 | B63 | B64 | |
|---------------------------------|----------------------|-------------------------|----------------------|---------------|-------------|--------------------|-----------------|---------------|---------------|
| | with extension piece | without extension piece | with extension piece | with screwing | with flange | without thermowell | without fitting | Straight Ø 14 | Straight Ø 14 |
| L100 | 0,52 | 0,37 | 0,47 | 0,65 | 1,5 | 0,52 | - | - | - |
| L110 | - | - | - | - | - | - | 0,32 | - | - |
| L160 | 0,53 | 0,39 | 0,49 | 0,7 | 1,54 | 0,53 | - | - | - |
| L170 | - | - | - | - | - | - | 0,33 | - | - |
| L230 | - | 0,39 | - | - | - | - | - | - | - |
| L240 | - | - | - | - | - | - | 0,34 | - | - |
| L250 | 0,55 | - | 0,53 | 0,75 | 1,59 | 0,55 | - | 0,69 | 0,69 |
| L300 | - | - | - | - | - | - | 0,35 | - | - |
| L310 | - | - | - | - | - | - | - | 0,8 | 0,8 |
| L380 | - | 0,42 | - | - | - | - | - | - | - |
| L390 | - | - | - | - | - | - | 0,37 | - | - |
| L400 | 0,58 | - | 0,58 | 0,8 | 1,68 | 0,58 | - | 0,98 | 0,98 |
| L500 | - | - | - | - | - | - | 0,39 | 1,17 | 1,17 |
| L530 | - | 0,46 | - | - | - | - | - | - | - |
| L540 | - | - | - | - | - | - | 0,4 | - | - |
| L630 | 0,63 | - | 0,63 | 0,95 | 1,82 | 0,63 | - | - | - |
| L710 | - | - | - | - | - | - | 0,42 | 1,57 | 1,57 |
| L770 | - | - | - | - | - | - | 0,43 | - | - |
| L800 | - | - | - | - | - | - | - | 1,75 | 1,75 |

Weight of sensors T1070 and T1570 without transmitter with head H1 [kg]

| Sensor version / Nominal Length | J13 | J23 | J33 | J43 | B00, B01 | B63 | B64 | |
|---------------------------------|----------------------|-------------------------|----------------------|---------------------------|--------------------|-----------------|---------------|---------------|
| | with extension piece | without extension piece | with extension piece | with screwing with flange | without thermowell | without fitting | Straight Ø 14 | Straight Ø 14 |
| L1000 | - | - | - | - | - | 0,48 | 2,14 | 2,14 |
| L1400 | - | - | - | - | - | 0,55 | 2,91 | 2,91 |
| L1600 | - | - | - | - | - | - | 3,3 | 3,3 |
| L2000 | - | - | - | - | - | 0,66 | 4,08 | 4,08 |

Weight of heads [kg]

| Head | J13 | J23 | J33 | J43 | B00, B01 | B63 | B64 |
|--------|------|------|------|------|----------|------|------|
| H2 | 0,04 | 0,04 | 0,04 | 0,04 | 0,04 | 0,04 | 0,04 |
| H3 | 0,05 | 0,05 | 0,05 | 0,05 | 0,05 | 0,05 | 0,05 |
| H4, H5 | 0,2 | 0,2 | 0,2 | 0,2 | 0,2 | - | 0,2 |
| H6 | 0,16 | 0,16 | 0,16 | 0,16 | 0,16 | - | 0,16 |
| H7 | 0,7 | 0,7 | 0,7 | 0,7 | 0,7 | - | 0,7 |

Weight of transmitters [kg]

| | |
|-------|------|
| P5310 | 0,04 |
| P5311 | 0,05 |
| 5335 | 0,05 |

5.2 Operation conditions

Maximal temperature of head (not for Ex version):

- 100 °C (without transmitter)
- 85 °C (with transmitter P5310, P5311 and 5335)

Maximal temperature of transition between stem of measuring insert and terminal block:

- 100 °C (in the short term 120 °C)



Ambient temperature of head Ta for Ex version (code ED/ET):

for temperature class T6 and max. surface temp. T80 °C:

- 50 ≤ Ta ≤ 75 °C for heads H6, H11, H13
- 50 ≤ Ta ≤ 70 °C for heads H7, H12, H14
- 40 ≤ Ta ≤ 75 °C for heads H5, H5N (only for dusts)

for temperature class T5 to Tx and max. surface temp T95 °C:

- 50 ≤ Ta ≤ 85 °C for heads H6, H7, H11, H12, H13, H14
- 40 ≤ Ta ≤ 85 °C for heads H5, H5N (only for dusts)



Ambient temperature of head Ta for Ex version (code EI):

for temperature class T5...T1 and max. surface temp. Tx:

- 50 ≤ Ta ≤ 85 °C for heads H6, H7, H11, H12, H13, H14
- 40 ≤ Ta ≤ 85 °C for heads H5, H5N

for temperature class T6:

- 50 ≤ Ta ≤ 75 °C for heads H6, H7, H11, H12, H13, H14
- 40 ≤ Ta ≤ 75 °C for heads H5, H5N

Maximal permissible operating properties of transmitter in the head for Ex version (codes ED / ET):

- I_{IMAX}: 30 mA
- P_{IMAX}: 1 W

Allowable load of protective tubes (codes B63, B64, B66, B73, B74, B83, B84, B85, B86, B84Z, B842, B843, B852, B853):
max. overpressure 100 kPa

Completion with thermowells for sensors designed for installation into thermowells

WT70 C Thermowell, cylindrical, PN 160, for screwing, for welding, with flange, inner bore 9; 7; 5; 3.5 mm, optional outer connection and inner thread, optional nominal length and material

WT70 T Thermowell, conical, PN 400, for screwing, inner bore 9; 6.25; 3.2 mm, optional inner and outer thread, optional nominal length and material

WT70 D Thermowell, conical, according to DIN 43772, PN 250, for welding, with flange, inside bore 9; 7; 3.5 mm, optional inner and outer thread, nominal length and material

Optional protective coating, wide range of accessories.

Detailed information can be found in data sheet No. 0993.

5.3 Metrological parameters

Temperature sensors ModuTEMP® 70 can be supplied:

- as sensors with calibration,
- as sensors without calibration.

Tolerance limits of accuracy classes are listed in EN 60751 for RTD and IEC 584-2 for TC. The initial tolerance is related to the initial calibration of the sensor. Drift of the sensor (RTD) meets the requirements of EN 60751, Sec. 6.5.3. To ensure accuracy of measurement, it is necessary to calibrate sensors periodically according to the operating parameters. Sensors can be supplied with calibration at several temperature points, according to customer requirements. Sensor to the transmitter can also be supplied with calibration including transmitter with current output signal of 4 to 20 mA.

5.4 Supplementary parameters

5.4.1 General

EMC (electromagnetic compatibility):
according to EN 61326-1

Lifetime:

Lifetime of the product cannot be exactly determined, it depends on the operational conditions.

It is necessary to take into account that lifetime (reliability) of the temperature sensors may be significantly reduced e.g. by chemical corrosiveness or abrasion or erosion effects of the measured medium, effects of vibrations or shocks and surges (caused by flowing of the medium or transferred to the sensor from the external environment, such as from big rotary machines, etc.), cyclic temperature changes, fast temperature changes, use of the sensors at the upper limit of the temperature range, etc.

Construction for severe applications

High level of housing IP 68 (heads H6 and H7), shock-proof replaceable measuring inserts with mineral-fibre insulation, all-stainless steel design including head (heads H7) and other characteristics allow to use these products in severe applications.

Stainless steel version

The basic price of the sensors includes main parts made of stainless steel 1.4541. In case that a stainless steel head H7 is chosen, such sensor can be used in a very corrosive environment of chemical production.



Heads and cable outlets of sensors into explosion hazard environment

Flameproof enclosure (code ED) is approved only for sensors with head H6 and H7.

Protection by enclosure (code ET) is approved only for sensors with head H6 and H7.

Intrinsically safe version (code EI) is supplied only for sensor versions with heads code H5, H5N, H6 and H7.

For sensors with version into explosion hazard environment (code ED, ET, EI) it is possible to use other cable glands than mentioned Ex cable glands in the ordering table. Other cable gland has to be with connection thread M20x1.5 and with individual approving.

When using cable glands (code KME1, KME2) designed for fixed cable installation, the cable shall be fixed against a possible rotation and displacements.

5.4.2 Version with transmitter

Sensors ModuTEMP® 70 may be completed with transmitters into heads (outer diameter of transmitter 44 mm; span of fixing screws M4 - 33 mm). For sensors with single sensor, it is possible to mount the transmitter directly on measuring insert flange (code S2 or S3) or into the head cover (only possible with heads H3, H4, H5) with cold junction with the terminal (code S1 or S5). Transmitter with diameter up to 64 mm can be also mounted into the head cover H4 and H5.



Using the transmitter in sensor head is possible if temperature of sensor head in place of application does not exceed max. allowed ambient temperature of transmitter. This temperature is typically 80 °C or 85 °C according to used transmitter. The temperature of the head

may be increased by transferring heat from the process. Therefore, it must be ensured such minimum length of uninsulated extension piece or sensor protection tube to prevent overheating of the transmitter mounted into the head. Temperature increase in sensor head compared to ambient temperature of head depending on the length of uninsulated extension piece and process temperature is determined for diameter of tube extension piece 11 to 14 mm according to Graph No. 3 and for diameter of tube extension piece 20 mm according to Graph No. 4.

Applicable transmitters

For range of transmitter see category optional accessories in transmitters for head mounting and the catalogue transmitters. For application in explosion hazard environment, transmitters with individual approval have to be selected.



For application with headmounted transmitter, observe also the requirements according to transmitter manual.

5.5 Restricting conditions for application in explosion hazard environment



User is obliged to ensure installation of temperature sensors in such a way, that there is no influence of external heat sources (measured medium, sun heating, etc.) on the surface of the sensor and its fittings that could lead to exceeding defined maximum surface temperature defined in EN 60079-0.

For codes ED, ET:

1. Maximum temperature of measured medium Tm for explosive gas atmospheres must not be higher than:

- 80°C for temperature class T6 (Ambient temperature Ta for T6: -50 to 75°C)
- 95°C for temperature class T5
- 130°C for temperature class T4
- 195°C for temperature class T3
- 290°C for temperature class T2
- 440°C for temperature class T1

For temperature of measured medium greater than the limit for temperature class T1 the maximum surface temperature Tx is determine from maximum temperature of measured medium Tm and safety addition of 10°C. Tx = Tm+10°C.

2. Maximum surface temperature Tx for explosive dust atmosphere equals temperature of measured medium Tm.
3. The ambient temperature of the head must be within the range specified in section 5.2 - Operating conditions.
4. Head of temperature sensor must be installed in such way, that no creepy discharge could occur.
5. Ex cable glands and Ex blanking elements shall be used with type of Ex protection.

For codes EI:

1. Product doesn't meet the 500 VAC test required by EN 60079-11 :2012. This must be taken into account when installing device.
2. For application requiring equipment with EPL Ga, Gb, Ge or Da, Db, De, the process pressure of the media shall range from 0.8 bar to 1.1 bar and the process temperatures from -40 °C to +100 °C. In case of a deviation from these operating conditions, it shall be considered that the values specifies in Specific Conditions of Use no. 4 and no 5. Are not exceeded at the sensor part of the product.
3. Maximum temperature of measured medium T_m for explosive gas atmospheres (EPL Ga, Gb, Ge) with regard to type and diameter of insert must not be higher than:

| Temperature class | Pt 100 (stem Ø D) | | Thermocouple |
|-------------------|-------------------|--------|--------------|
| | 3 and 4,5 mm | 6 mm | |
| T6 | 62 °C | 75 °C | 78 °C |
| T5 | 77 °C | 90 °C | 93 °C |
| T4 | 112 °C | 125 °C | 128 °C |
| T3 | 177 °C | 190 °C | 193 °C |
| T2 | 272 °C | 285 °C | 288 °C |
| T1 | 422 °C | 435 °C | 438 °C |

Surface temperature Tx for process media temperature T_m higher than the limit for temperature class T1 for explosive gas atmospheres (EPL Ga, Gb, Ge) with regard to type and diameter of insert::

| Surface temperature | Pt 100 (stem Ø D) | | Thermocouple |
|---------------------|------------------------|------------------------|------------------------|
| | 3 and 4,5 mm | 6 mm | |
| T _x (°C) | T _m + 28 °C | T _m + 15 °C | T _m + 12 °C |

4. Surface temperature T_{200X} under 200 mm layer of dust for explosive dust atmosphere (EPL Da, Db, Dc) with regard to type and diameter of insert and process media temperature T_m:

| Surface temperature | Pt 100 (stem Ø D) | | Thermocouple |
|------------------------|------------------------|------------------------|-----------------------|
| | 3 and 4,5 mm | 6 mm | |
| T _{200X} (°C) | T _m + 28 °C | T _m + 10 °C | T _m + 2 °C |

Surface temperature Tx without layer of dust for explosive dust atmosphere (EPL Db, De) with regard to type and diameter of insert and process media temperature T_m:

| Surface temperature | Pt 100 (stem Ø D) | | Thermocouple |
|---------------------|------------------------|-----------------------|-----------------------|
| | 3 and 4,5 mm | 6 mm | |
| T _x (°C) | T _m + 18 °C | T _m + 5 °C | T _m + 2 °C |

5. The product enclosure includes accessible non-metallic parts. Due to the possibility of the electrostatic charging while subjected to a prolific charge generating mechanism, the end user shall determine suitability in the specific application in explosive dust atmosphere.

Chart no. 3

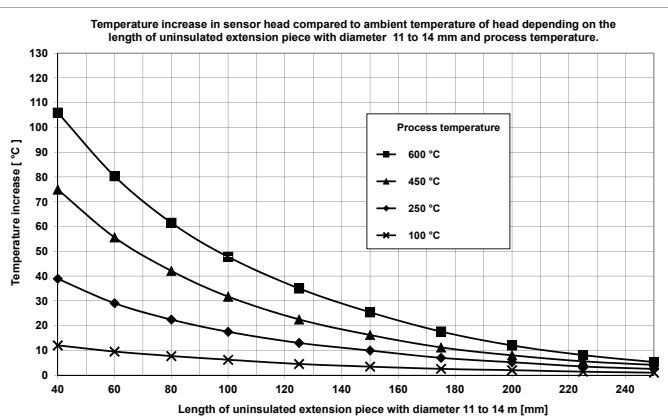
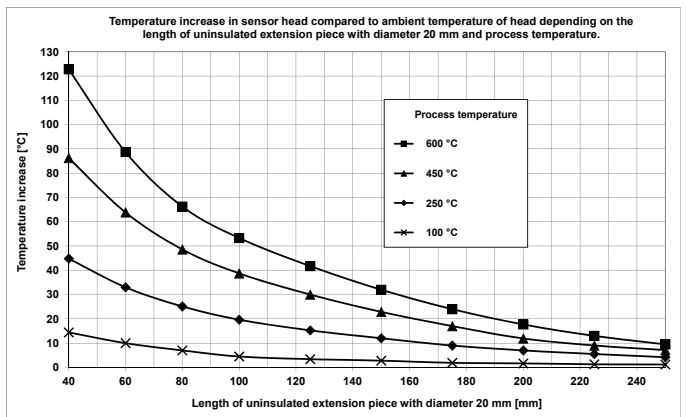

Chart no. 4



6. Tests, certificates, standards and marking

6.1 Tests and certificates

Temperature sensors ModuTEMP® 70 have the following certificates and approvals:

EU Certificate on type examination, No. FTZÚ 03 ATEX 0297X with appendix No. 8 dated 22. 12. 2023.

For explosion hazard environment of gasses and dusts are approved these versions Exd a Ext:

Versions with thermowell

T1070/T1570..J23/J32/J33/J63/J99..ED/ET

and straight versions

T1070/T1570..B5x/B6x/B7x/B8x/B99.. ED/ET

for heads H6/H7/H11/H12/H13/H14

with marking:

⊕ II 1/2G Ex db IIC T6...Tx°C Ga/Gb

for heads H5N/H5/H6/H7/H11/H12/H13/H14

with marking:

⊕ II 1/2D Ex ta/tb IIIC T90°C...Tx°C Da/Db

Versions into thermowell

T1070/T1570..J13/J16/J21P/J19..ED/ET

for heads H6/H7/H11/H12/H13/H14

with marking:

⊕ II 2G Ex db IIC T6...Tx°C Gb

for heads H5N/H5/H6/H7/H11/H12/H13/H14

with marking:

⊕ II 2D Ex tb IIIC T90°C...Tx°C Db

Spatial version

T1070..P1E..ED/ET

for heads H6/H7/H11/H12/H13/H14

with marking:

⊕ II 2G Ex db IIC T6...T5 Gb

for heads H5N/H5/H6/H7/H11/H12/H13/H14

with marking:

⊕ II 2D Ex tb IIIC T90°C Db

EU Certificate on type examination, No. FTZÚ 13

ATEX0080X with appendix No. 3 dated 22. 12. 2023.

For explosion hazard environment of gasses and dusts are approved these versions Exi with heads H5N/H5/H6/H7/H11/H12/H13/H14:

Versions into thermowell

T1070/T1570..J13/J16/J21P/J19..EI

with marking:

⊕ II 2G Ex ia IIC T6...Tx°C Gb

⊕ II 2D Ex ia IIIC T85°C...Tx°C Db

Spatial version

T1070..P1E..EI

with marking:

⊕ II 2G Ex ia IIC T6...T5°C Gb

⊕ II 2D Ex ia IIIC T85°C...Tx°C Db

Other standard versions

T1070/T1570..(except J13 and P1E)..EI

with marking:

⊕ II 1/2G Ex ia IIC T6...Tx°C Ga/Gb

⊕ II 1/2D Ex ia IIIC T₂₀₀85°C...T₂₀₀X°C Da/Db

Certificate of conformity

Certified are these types of resistance and thermocouple temperature sensors: T10xx and T15xx (series production).

6.2 Standards and directives

RoHS:

2011/65/EU

Electromagnetic compatibility:

EN 61326-1

Sensors into explosion hazard environment:

EN 60079-0, EN 60079-1, EN 60079-10-1, EN 60079-10-2, EN 60079-11, EN 60079-14, EN 60079-26, EN 60079-31

6.3 Marking and type tag information

Marking on temperature sensors head

Standard version – aluminium or stainless steel tag (example):

RTD

T1070 06 F2 J13 L100 type number (version number)
 – incomplete marking

1xPT100/B/4 number of sensors, sensor material,
 value of basic resistance, accuracy
 version of inside wiring

TC

T1570 21 T7 J13 L100 number type (version number)
 – incomplete marking

1xJ/2 number of sensors, sensor
 material, accuracy class,

-70 ... 500 °C temperature range

3214567 serial number

IP 65 housing

JSP, s.r.o.
 Raisova 547
 506 01 Jičín
 Czech Republic address of manufacturer

 logo JSP, s.r.o.

www.jsp.cz website address

CE marking of conformity

Tag of explosion hazard environment version (codes ED, ET, EI)

This tag include in addition to the standard version this extra information:

2024 year of manufacture



symbol of warning

FTZÚ 13 ATEX 0297X number of EC certificate on type
 examination

Ⓔ II 2G Ex db IIC T6...Tx°C Gb
 marking of explosion proof
 equipment

CE1026 marking of conformity with number
 of notification authority, that made
 approval

The head cover of flameproof enclosure (code ED) and protection by enclosure version (code ET) has also a self-adhesive label with warning:

DO NOT OPEN UNDER VOLTAGE!

7. Ordering information

7.1 Ordering table of version with thermowell

| Type | | 1 | 2 | 3 | 4 | 5 | 6 | 7 | 8 | 9 | ○ |
|---------|---|---|---|---|---|---|---|---|---|---|---|
| 1. code | Description | | | | | | | | | | |
| T1070 | Resistance temperature sensor with thermowell | | | | | | | | | | |
| T1570 | Thermocouple temperature sensor with thermowell | | | | | | | | | | |

| Temperature sensor | | | | 1 | 2 | 3 | 4 | 5 | 6 | 7 | 8 | 9 | ○ |
|--------------------|--|-----------------|-------------------------|---|---|---|---|---|---|---|---|---|---|
| 2. code | Resistance (RTD) | Sheath material | Max. temperature of use | | | | | | | | | | |
| 04 | 1× Pt100, two-wire inside wiring | 1.4404 | up to 500 °C | | | | | | | | | | |
| 06 | 1× Pt100, four-wire inside wiring | 1.4404 | up to 600 °C | | | | | | | | | | |
| 06HT | 1× Pt100, four-wire inside wiring <small>only for code F7</small> | Inconel 600 | up to 700 °C | | | | | | | | | | |
| 07 | 2× Pt100, three-wire inside wiring | 1.4404 | up to 600 °C | | | | | | | | | | |
| 08 | 2× Pt100, two-wire inside wiring | 1.4404 | up to 500 °C | | | | | | | | | | |
| 09 | 2× Pt100, four-wire inside wiring <small>only for codes S4 and S5</small> | 1.4404 | up to 600 °C | | | | | | | | | | |

| Temperature sensor | | | | 1 | 2 | 3 | 4 | 5 | 6 | 7 | 8 | 9 | ○ |
|--------------------|---|-------------------|-----------------------|---|---|---|---|---|---|---|---|---|---|
| 2. code | Thermocouple (TC) | Sheath material | Measuring range | | | | | | | | | | |
| 20 | 1× "T" (Cu-CuNi), insulated | 1.4541 | -40 (-200) to +350 °C | | | | | | | | | | |
| 21 | 1× "J" (Fe-CuNi), insulated | 1.4541 | -40 to +800 °C | | | | | | | | | | |
| 61 | 2× "J" (Fe-CuNi), insulated, isolated junctions | 1.4541 | -40 to +800 °C | | | | | | | | | | |
| 22 | 1× "K" (NiCr-NiAl), insulated | Inconel 600 | -40 (-200) to 1100 °C | | | | | | | | | | |
| 62 | 2× "K" (NiCr-NiAl), insulated, isolated junctions | Inconel 600 | -40 (-200) to 1100 °C | | | | | | | | | | |
| 23 | 1× "N" (NiCrSi-NiSi), insulated | Inconel 600 | -40 (-200) to 1100 °C | | | | | | | | | | |
| 63 | 2× "N" (NiCrSi-NiSi), insulated, isolated junctions | Inconel 600 | -40 (-200) to 1100 °C | | | | | | | | | | |
| 22HT | 1× "K" (NiCr-NiAl), insulated | Nicrobell/Pyrosil | -40 to 1300 °C | | | | | | | | | | |
| 62HT | 2× "K" (NiCr-NiAl), insulated, isolated junctions | Nicrobell/Pyrosil | -40 to 1300 °C | | | | | | | | | | |
| 23HT | 1× "N" (NiCrSi-NiSi), insulated | Nicrobell/Pyrosil | -40 to 1300 °C | | | | | | | | | | |
| 63HT | 2× "N" (NiCrSi-NiSi), insulated, isolated junctions | Nicrobell/Pyrosil | -40 to 1300 °C | | | | | | | | | | |
| L U | Grounded version of junction TC | | | | | | | | | | | | |
| 99 | Other | | | | | | | | | | | | |

| Accuracy class | | | | 1 | 2 | 3 | 4 | 5 | 6 | 7 | 8 | 9 | ○ |
|----------------|---|---|-----------------|---|---|---|---|---|---|---|---|---|---|
| 3. code | Resistance (RTD) according to EN 60751 | Inside wiring material | Measuring range | | | | | | | | | | |
| F1 | B <small>not for code 06HT</small> | Cu | -50 to +300 °C | | | | | | | | | | |
| F2 | B <small>not for code 06HT</small> | Cu | -70 to +500 °C | | | | | | | | | | |
| F3 | B <small>only for codes 06, 07 and 09</small> | Ni *1 | -200 to +600 °C | | | | | | | | | | |
| F7 | B <small>only for code 06HT</small> | Ni *1 | -200 to +700 °C | | | | | | | | | | |
| F4 | A <small>only for codes 06, 07 and 09</small> | Cu | -30 to +300 °C | | | | | | | | | | |
| F5 | A <small>only for codes 06, 07 and 09</small> | Cu | -100 to +450 °C | | | | | | | | | | |
| F9 | Other | | | | | | | | | | | | |
| 3. code | Thermocouple (TC) according to EN 60584-1 | Measuring range | | | | | | | | | | | |
| T8 | 3 | -200 to +40 °C | | | | | | | | | | | |
| T7 | 2 | -40 to 350 °C ("T") / 800 °C ("J") / 1200 °C ("K", "N") | | | | | | | | | | | |
| T6 | 1 <small>not for TC "N" with KV</small> | -40 to 350 °C ("T") / 750 °C ("J") / 1000 °C ("K", "N") | | | | | | | | | | | |
| T9 | Other | | | | | | | | | | | | |

*1 - Not allowable to use two-wire connection because of nickel inner wiring.

| Fitting of the sensor ① ② ③ ④ ⑤ ⑥ ⑦ ⑧ ⑨ ⑩ | | | |
|--|--|-----------------------------|------------------|
| 4. code | Description *1 | Diameter of extension piece | Fitting material |
| J23 | With thermowell Ø 9 × 1 mm, PN 63 | 14 × 2,5 mm | 1.4541 |
| J32 | With thermowell Ø 11 × 2 mm reduced to Ø 6 × 1,3 mm, PN 100 | 11 × 2 mm | 1.4541 |
| J33 | With thermowell Ø 11 × 2 mm, PN 100 | 11 × 2 mm | 1.4541 |
| J63 | With thermowell Ø 14 × 2,5 mm reduced to Ø 11 × 2,4 mm, PN 160 | 14 × 2,5 mm | 1.4541 |
| J99 | Other with thermowell | | |

*1 - Max. use temperature up to +600 °C; for medium pressure up to 1 bar and for low flow velocity it can be used up to + 800 °C.

| Nominal immersion of sensor ① ② ③ ④ ⑤ ⑥ ⑦ ⑧ ⑨ ⑩ | | |
|--|---|-------------------|
| 5. code | Dimension L | |
| L100 | 100 mm | |
| L160 | 160 mm | |
| L250 | 250 mm | not for J23 N000 |
| L400 | 400 mm | not for J23 N000 |
| L630 | 630 mm | not for J23 N000 |
| L230 | 230 mm | only for J23 N000 |
| L380 | 380 mm | only for J23 N000 |
| L530 | 530 mm | only for J23 N000 |
| L_ | Other (please fill nominal immersion of sensor in mm) | |

| Head ① ② ③ ④ ⑤ ⑥ ⑦ ⑧ ⑨ ⑩ | | |
|---|---|---|
| 6. code | Description | |
| H1 | Al alloy, cable outlet M20×1.5 for cable Ø 4 to 12.5 mm, IP 65 | |
| H2 | Al alloy, cable outlet M20×1.5 for cable Ø 4 to 12.5 mm, IP 65 | |
| H3 | Al alloy, with high cap for mounting of transmitter with Ø 44 mm, cable outlet M20×1.5 for cable Ø 4 to 12.5 mm, IP 65 | |
| H4N | Al alloy, with low cap, cable outlet M20×1.5 for cable Ø 4 to 12.5 mm, IP 65 | |
| H4 | Al alloy, with high cap for mounting of transmitter with Ø 62 mm, cable outlet M20×1.5 for cable Ø 4 to 12.5 mm, IP 65 | |
| H5N | Al alloy, with low cap, ground clamps, cable outlet M20×1.5 for cable Ø 5 to 10 m, IP 65 | |
| H5 | Al alloy, with high cap for mounting of transmitter with Ø 62 mm, ground clamps, cable outlet M20×1.5 for cable Ø 5 to 10 mm, IP 65 | |
| H5PA | Polyamide, with high cap for mounting of transmitter with Ø 62 mm, Tmax 80 °C, cable outlet M20×1.5 for cable Ø 4 to 12.5 mm, IP 65 | |
| H6 | Al alloy, ground clamps, thread for cable outlet M20×1.5, IP 68 | |
| H7 | Stainless steel, ground clamps, thread for cable outlet M20×1.5, IP 68 | |
| H11 | Al alloy, screw cap with chain, without cable gland, ground clamps, IP68 | |
| H12 | Stainless steel AISI316, screw cap with chain, without cable gland, ground clamps, IP68 | |
| H13 | Al alloy, screw cap with peephole, without cable gland, IP68 | |
| H14 | Stainless steel AISI316, screw cap with peephole, without cable gland, IP68 | |
| L D | Double cable outlet | only for codes H4, H4N, H5, H5N |
| L W | Sensor head with peephole for display | only for codes H4 Z1, H4D Z1, H5 Z1E a S2; ne pro dvojité čidla |
| H9 | Other | |

| Cold-end of measuring insert ① ② ③ ④ ⑤ ⑥ ⑦ ⑧ ⑨ ⑩ | |
|---|---|
| 7. code | Description |
| S1 | With ceramic terminal block (diameter 42 mm) on flange of measuring insert |
| S2 | For single sensor, without terminal block, with set for mounting of transmitter on flange of measuring insert (instead of terminal block) |

| 7. code | Description |
|---------|---|
| S4 | For double sensor, without terminal block, with set for mounting of two transmitters not suitable for H1, H2, H5N, H6 and H7 |
| S5 | With ceramic terminal block (diameter 42 mm), embedded pins (according to NAMUR) |
| S9 | Other |

| Extension piece ① ② ③ ④ ⑤ ⑥ ⑦ ⑧ ⑨ ○ | | |
|--|---|---------------------------------------|
| 8. code | Nominal length of extension piece - N | Max. temperature of connection thread |
| N000 | Without extension piece N=15 mm *1 | 120 °C |
| N145 | With extension piece N=145 mm | 600 °C |
| N___ | Other (please fill nominal length of extension piece in mm) | |

*1 - Sensor head is NOT POSSIBLE to turn with cable outlet to the to the desired position after installation to the technology.

| Process connection ① ② ③ ④ ⑤ ⑥ ⑦ ⑧ ⑨ ○ | | |
|---|---------------------|-----------------------|
| 9. code | for J23 | for J32, J33, J63 |
| P3 | Male thread M20×1,5 | Male thread M20×1,5 |
| P4 | - | Male thread M27×2 |
| P5 | Male thread G1/2" | Male thread G1/2" |
| P6 | - | Male thread G3/4" |
| P7 | Male thread 1/2"NPT | Male thread 1/2"NPT |
| P8 | - | Flat flange DN20/PN40 |
| P9 | Other | Other |

| Optional versions and accessories ① ② ③ ④ ⑤ ⑥ ⑦ ⑧ ⑨ ● | | |
|--|---|--|
| Code | Versions for explosive atmosphere of gasses or dusts | |
| | Flameproof enclosure "Ex d" only for gasses and protection by enclosure "Ex t" only for dusts, intrinsically safe version "Ex i" for gasses and dusts | |
| ED/ET | (Ex) II 1/2G Ex db IIC T6...Tx°C Ga/Gb, (Ex) II 1/2D Ex ta/tb IIIC T90°C...Tx°C Da/Db | only for heads H6, H7, H11, H12, H13, H14 |
| EI | (Ex) II 1/2G Ex ia IIC T6...Tx°C Ga/Gb, (Ex) II 1/2D Ex ia IIIC T20085°C...T200x°C Da/Db | only for heads H5, H5N, H6, H7, H11, H12, H13, H14 |
| ET | (Ex) II 1/2D Ex ta/tb IIIC T90°C...Tx°C Da/Db | pouze pro hlavice s kódy H5, H5N |

| Code | Protective spray | T _{MAX} (with spray) |
|------|---|--|
| X01 | polyamid PA11 | 100 °C *1 |
| X02 | ethylen-chlorotrifluorethylen E-CTFE "Halar" | 170 °C *1 |
| X03 | perfluoralkoxy - kopolymer tetrafluorethylenu a perfluorovaného vinylétheru PFA | 260 °C *1 |
| X04 | ethylen tetrafluorethylen ETFE "Hyflon" | 130 °C *1 |
| X05 | polytetrafluorethylen PTFE | 260 °C *1 |
| X07 | Hard metal coating (Fe-Cr-Mn-Si-B-C) for abrasive medium | 925 °C |
| X08 | Corundum spray for intense abrasive medium | according to specific composition of coating |
| X99 | Other | |

*1 - Depends on measured medium.

| Code | Indication units |
|------|---|
| Z1 | LED display mounted in sensor head only for code H4(D)W and S2, S3; operating temperature -20 to +80 °C |
| Z1E | Intrinsically safe LED display in sensor head (Ex) II 2G Ex ia IIC T6 only for codes H5W and S2, S3; operating temperature -20 to +80 °C |

| Code | Cable outlet *1 |
|------|---|
| KM1 | Cable outlet, nickel-plated brass, IP 68, M20×1.5, for cable Ø 5 to 10 mm standard for H6, H7 |
| KM4 | Cable outlet, stainless steel, IP 68, M20×1.5, for cable Ø 7 to 12 mm |
| KME1 | Cable outlet, nickel-plated brass, Ex d, M20×1.5, IP 68, for fixed assembly cable Ø 4.5 to 8.5 mm |
| KME2 | Cable outlet, nickel-plated brass, Ex d, M20×1.5, IP 68, for fixed assembly cable Ø 7 to 12 mm |

| Code | Cable outlet ^{*1} |
|-------------|--|
| KME3 | Cable outlet, stainless steel, Ex d, M20×1.5, IP 68, for fixed assembly cable Ø 4 to 8 mm |
| KME5 | Cable outlet, polyamide (light blue), Ex e, M20×1.5, IP 68, for fixed assembly cable Ø 5 to 9 mm, operating temperature -20 to +95 °C not for H5PA |
| KME6 | Cable outlet, polyamide (light blue), Ex e, M20×1.5, IP 68, for fixed assembly cable Ø 6.5 to 12 mm, operating temperature -20 to +95 °C not for H5PA |
| KM9 | Other |
| PK1 | Lock anti pull-up cable for Ex d cable outlet KME1 |
| PK2 | Lock anti pull-up cable for Ex d cable outlet KME2 |

*1 - The heads H1, H2, H3, H4, H4N, H5, H5N are usually equipped with nickel-plated brass cable outlet for cable with diameter 4 to 12.5 mm.

| Code | Snap lock |
|-----------|---|
| RU | Snap lock only with codes H2, H4, H4N, H5, H5N |

| Code | Calibration in customer defined points, including certificate of calibration |
|----------------|---|
| KTE31A | Resistance temperature sensor calibration in three points in range -40 to +660 °C |
| KTE51A | Resistance temperature sensor calibration in five points in range -40 to +660 °C |
| KTE32AA | Thermocouple temperature sensor calibration in three points in range -40 to +660 °C |
| KTE52AA | Thermocouple temperature sensor calibration in five points in range -40 to +660 °C |
| KTE9 | Other |

| Code | Extended warranty |
|-------------|---|
| WE36 | Product warranty 36 months not for code VR |
| WE__ | Other (the number of months must be added to the code) not for code VR |

| Code | Accessories |
|------------|---|
| BZS | Stainless steel tag for attachment (70×15 mm) with laser description according to the order |
| PPZ | Laser description of sensor according to the order |
| Q1 | Material certificate according to EN 10204, 3.1 |

Example of order:

T1070 04 F2 J33 L160 H3 S1 N145 P3 KTE31A (-40, 200, 500 °C)

7.2 Ordering table of version into thermowell

| Type ① ② ③ ④ ⑤ ⑥ ⑦ ⑧ ⑨ ⑩ ○ | | | |
|---|---|--|--|
| 1. code | Description | | |
| T1070 | Resistance temperature sensor into thermowell | | |
| T1570 | Thermocouple temperature sensor into thermowell | | |

| Temperature sensor ① ② ③ ④ ⑤ ⑥ ⑦ ⑧ ⑨ ○ | | | |
|---|--|-------------------|-------------------------|
| 2. code | Resistance (RTD) | Sheath material | Max. temperature of use |
| 04 | 1× Pt100, two-wire inside wiring | 1.4404 | up to 500 °C |
| 06 | 1× Pt100, four-wire inside wiring | 1.4404 | up to 600 °C |
| 06HT | 1× Pt100, four-wire inside wiring <small>only for code F7</small> | Inconel 600 | up to 700 °C |
| 07 | 2× Pt100, three-wire inside wiring | 1.4404 | up to 600 °C |
| 08 | 2× Pt100, two-wire inside wiring | 1.4404 | up to 500 °C |
| 09 | 2× Pt100, four-wire inside wiring <small>only for codes S4 and S5</small> | 1.4404 | up to 600 °C |
| L VR | Increased resistance to vibration and shock <small>only for code 06 F2 ... S5</small> | | |
| 2. code | Thermocouple (TC) | Sheath material | Measuring range |
| 20 | 1× "T" (Cu-CuNi), insulated | 1.4541 | -40 (-200) to +350 °C |
| 21 | 1× "J" (Fe-CuNi), insulated | 1.4541 | -40 to +800 °C |
| 61 | 2× "J" (Fe-CuNi), insulated, isolated junctions | 1.4541 | -40 to +800 °C |
| 22 | 1× "K" (NiCr-NiAl), insulated | Inconel 600 | -40 (-200) to 1100 °C |
| 62 | 2× "K" (NiCr-NiAl), insulated, isolated junctions | Inconel 600 | -40 (-200) to 1100 °C |
| 23 | 1× "N" (NiCrSi-NiSi), insulated | Inconel 600 | -40 (-200) to 1100 °C |
| 63 | 2× "N" (NiCrSi-NiSi), insulated, isolated junctions | Inconel 600 | -40 (-200) to 1100 °C |
| 22HT | 1× "K" (NiCr-NiAl), insulated | Nicrobell/Pyrosil | -40 to 1300 °C |
| 62HT | 2× "K" (NiCr-NiAl), insulated, isolated junctions | Nicrobell/Pyrosil | -40 to 1300 °C |
| 23HT | 1× "N" (NiCrSi-NiSi), insulated | Nicrobell/Pyrosil | -40 to 1300 °C |
| 63HT | 2× "N" (NiCrSi-NiSi), insulated, isolated junctions | Nicrobell/Pyrosil | -40 to 1300 °C |
| L U | Grounded version of junction TC | | |
| 99 | Other | | |

| Accuracy class ① ② ③ ④ ⑤ ⑥ ⑦ ⑧ ⑨ ○ | | | |
|---|---|---|-----------------|
| 3. code | Resistance (RTD) according to EN 60751 | Inside wiring material | Measuring range |
| F1 | B <small>not for code 06HT</small> | Cu | -50 to +300 °C |
| F2 | B <small>not for code 06HT</small> | Cu | -70 to +500 °C |
| F3 | B <small>only for codes 06, 07 and 09</small> | Ni *1 | -200 to +600 °C |
| F7 | B <small>only for code 06HT</small> | Ni *1 | -200 to +700 °C |
| F4 | A <small>only for codes 06, 07 and 09</small> | Cu | -30 to +300 °C |
| F5 | A <small>only for codes 06, 07 and 09</small> | Cu | -100 to +450 °C |
| F9 | Other | | |
| 3. code | Thermocouple (TC) according to EN 60584-1 | Measuring range | |
| T8 | 3 | -200 to +40 °C | |
| T7 | 2 | -40 to 350 °C ("T") / 800 °C ("J") / 1200 °C ("K", "N") | |
| T6 | 1 <small>not for TC "N" with KV</small> | -40 to 350 °C ("T") / 750 °C ("J") / 1000 °C ("K", "N") | |
| T9 | Other | | |

*1 - Not allowable to use two-wire connection because of nickel inner wiring.

Fitting of the sensor ① ② ③ ④ ⑤ ⑥ ⑦ ⑧ ⑨ ⑩

| 4. code | Description *1 | Diameter of extension piece | Fitting material |
|---------|---|-----------------------------|------------------|
| J13 | Into thermowell | 14 × 2,5 mm | 1.4541 |
| J16 | Into thermowell | 20 × 3 mm | 1.4541 |
| J16WH | Into thermowell, with 6HR 27 mm welded to the adapter under the sensor head | 20 × 3 mm | 1.4541 |
| J21P | Into thermowell, with rotary fitting in the middle of extension piece *2 | 21,3 × 2,6 mm | 1.4541 |
| J19 | Other into thermowell | | |

*1 - Max. temperature of connection thread is 600 °C. *2 - Spring stroke of insert 15 mm.

Nominal immersion of sensor ① ② ③ ④ ⑤ ⑥ ⑦ ⑧ ⑨ ⑩

| 5. code | Dimension L |
|---------|---|
| L100 | 100 mm |
| L160 | 160 mm |
| L165 | 165 mm |
| L195 | 195 mm |
| L250 | 250 mm |
| L255 | 255 mm |
| L400 | 400 mm |
| L405 | 405 mm |
| L630 | 630 mm |
| L_ | Other (please fill nominal immersion of sensor in mm) |

Head ① ② ③ ④ ⑤ ⑥ ⑦ ⑧ ⑨ ⑩

| 6. code | Description |
|---------|--|
| H1 | Al alloy, cable outlet M20×1.5 for cable Ø 4 to 12.5 mm, IP 65 |
| H2 | Al alloy, cable outlet M20×1.5 for cable Ø 4 to 12.5 mm, IP 65 |
| H3 | Al alloy, with high cap for mounting of transmitter with Ø 44 mm, cable outlet M20×1.5 for cable Ø 4 to 12.5 mm, IP 65 |
| H4N | Al alloy, with low cap, cable outlet M20×1.5 for cable Ø 4 to 12.5 mm, IP 65 |
| H4 | Al alloy, with high cap for mounting of transmitter with Ø 62 mm, cable outlet M20×1.5 for cable Ø 4 to 12.5 mm, IP 65 |
| H5N | Al alloy, with low cap, ground clamps, cable outlet M20×1.5 for cable Ø 5 to 10 mm, IP 65 |
| H5 | Al alloy, with high cap for mounting of transmitter with Ø 62 mm, ground clamps, cable outlet M20×1.5 for cable Ø 5 to 10 mm, IP 65 |
| H5PA | Polyamide, with high cap for mounting of transmitter with Ø 62 mm, Tmax 80 °C, cable outlet M20×1.5 for cable Ø 4 to 12.5 mm, IP 65 |
| H6 | Al alloy, ground clamps, thread for cable outlet M20×1.5, IP 68 |
| H7 | Stainless steel, ground clamps, thread for cable outlet M20×1.5, IP 68 |
| H11 | Al alloy, screw cap with chain, without cable gland, ground clamps, IP68 |
| H12 | Stainless steel AISI316, screw cap with chain, without cable gland, ground clamps, IP68 |
| H13 | Al alloy, screw cap with peephole, without cable gland, IP68 |
| H14 | Stainless steel AISI316, screw cap with peephole, without cable gland, IP68 |
| L D | Double cable outlet only for codes H4, H4N, H5, H5N |
| L W | Sensor head with peephole for display only for codes H4 Z1, H4D Z1, H5 Z1E a S2; ne pro dvojité čidla |
| H9 | Other |

Cold-end of measuring insert ① ② ③ ④ ⑤ ⑥ ⑦ ⑧ ⑨ ⑩

| 7. code | Description |
|---------|--|
| S1 | With ceramic terminal block (diameter 42 mm) on flange of measuring insert only for diameter 6 mm (code D3, D5) |

| 7. code | Description |
|---------|---|
| S2 | For single sensor, without terminal block, with set for mounting of transmitter on flange of measuring insert (instead of terminal block) |
| S4 | For double sensor, without terminal block, with set for mounting of two transmitters not for J21P, not suitable for H1, H2, H5N, H6 and H7 |
| S5 | With ceramic terminal block (diameter 42 mm), embedded pins (according to NAMUR) |
| S9 | Other |

Measuring insert diameter

1 2 3 4 5 6 7 8 9 10

| 8. code | Description |
|---------|---|
| D1 | 3 mm not for J21P and 2×Pt100/4-wire (code 09) and code 06HT |
| D2 | 4,5 mm not for J21P, resistance sensors and TC "T" |
| D3 | 6 mm |
| D5 | 6 mm with distance sleeve 8 mm |
| D9 | Other |

Extension piece

1 2 3 4 5 6 7 8 9 10

| 9. code | Nominal length of extension piece - N | Max. temperature of connection thread |
|---------|---|---------------------------------------|
| N000 | Without extension piece N=15 mm *1 | 120 °C |
| N140 | With extension piece N=140 mm standard version for L=165, 195, 255 a 405 mm | 600 °C |
| N145 | With extension piece N=145 mm standard version for L=100, 160, 250, 400 a 630 mm | 600 °C |
| N___ | Other (please fill nominal length of extension piece in mm) | |

*1 - Sensor head is NOT POSSIBLE to turn with cable outlet to the to the desired position after installation to the technology.

Process connection

1 2 3 4 5 6 7 8 9 10

| 10. code | for J13 | for J16, J21P |
|----------|---------------------|---------------------|
| P1 | male thread M14×1.5 | - |
| P2 | male thread M18×1.5 | - |
| P3 | male thread M20×1.5 | male thread M20×1.5 |
| P5 | male thread G1/2" | male thread G1/2" |
| P7 | male thread 1/2"NPT | male thread 1/2"NPT |
| P9 | other | other |

Optional accessories

1 2 3 4 5 6 7 8 9 10

| Code | Versions for explosive atmosphere of gasses or dusts |
|-------|---|
| | Flameproof enclosure "Ex d" only for gasses and protection by enclosure "Ex t" only for dusts, intrinsically safe version "Ex i" for gasses and dusts |
| ED/ET | (Ex) II 2G Ex db IIC T6...Tx°C Gb, (Ex) II 2D Ex tb IIIC T90°C...Tx°C Db only for heads H6, H7, H11, H12, H13, H14 |
| EI | (Ex) II 2G Ex ia IIC T6...Tx°C Gb, (Ex) II 2D Ex ia IIIC T85°C...Tx°C Db only for heads H5, H5N, H6, H7, H11, H12, H13, H14 |
| ET | (Ex) II 2D Ex tb IIIC T90°C...Tx°C Db only for heads H5, H5N |

| Code | Protective spray | T _{MAX} (with spray) |
|------|--|--|
| X01 | polyamid PA11 | 100 °C (depends on measured medium) |
| X02 | ethylen-chlortrifluorethylen E-CTFE "Halar" | 170 °C (depends on measured medium) |
| X03 | perfluoralkoxy - kopolymer tetrafluorethylen u perfluorovaného vinylétheru PFA | 260 °C (depends on measured medium) |
| X04 | ethylentetrafluorethylen ETFE "Hyflon" | 130 °C (depends on measured medium) |
| X05 | polytetrafluorethylen PTFE | 260 °C (depends on measured medium) |
| X07 | Hard metal coating (Fe-Cr-Mn-Si-B-C) for abrasive medium | 925 °C |
| X08 | Corundum spray for intense abrasive medium | according to specific composition of coating |

| Code | Protective spray | T _{MAX} (with spray) |
|--|--|-------------------------------|
| X99 | Other | |
| Code | Indication units | |
| Z1 | LED display mounted in sensor head only for code H4(D)W and S2, S3; operating temperature -20 to +80 °C | |
| Z1E | Intrinsically safe LED display in sensor head (Ex) II 2G Ex ia IIC T6 only for codes H5W and S2, S3; operating temperature -20 to +80 °C | |
| Code | Cable outlet *1 | |
| KM1 | Cable outlet, nickel-plated brass, IP 68, M20×1.5, for cable Ø 5 to 10 mm standard for H6, H7 | |
| KM4 | Cable outlet, stainless steel, IP 68, M20×1.5, for cable Ø 7 to 12 mm | |
| KME1 | Cable outlet, nickel-plated brass, Ex d, M20×1.5, IP 68, for fixed assembly cable Ø 4.5 to 8.5 mm | |
| KME2 | Cable outlet, nickel-plated brass, Ex d, M20×1.5, IP 68, for fixed assembly cable Ø 7 to 12 mm | |
| KME3 | Cable outlet, stainless steel, Ex d, M20×1.5, IP 68, for fixed assembly cable Ø 4 to 8 mm | |
| KME5 | Cable outlet, polyamide (light blue), Ex e, M20×1.5, IP 68, for fixed assembly cable Ø 5 to 9 mm, operating temperature -20 to +95 °C not for H5PA | |
| KME6 | Cable outlet, polyamide (light blue), Ex e, M20×1.5, IP 68, for fixed assembly cable Ø 6.5 to 12 mm, operating temperature -20 to +95 °C not for H5PA | |
| KM9 | Other | |
| PK1 | Lock anti pull-up cable for Ex d cable outlet KME1 | |
| PK2 | Lock anti pull-up cable for Ex d cable outlet KME2 | |
| *1 – The heads H1, H2, H3, H4, H4N, H5, H5N are usually equipped with nickel-plated brass cable outlet for cable with diameter 4 to 12.5 mm. | | |
| Code | Snap lock | |
| RU | Snap lock only with codes H2, H4, H4N, H5, H5N | |
| Code | Calibration in customer defined points, including certificate of calibration | |
| KTE31A | Resistance temperature sensor calibration in three points in range -40 to +660 °C | |
| KTE51A | Resistance temperature sensor calibration in five points in range -40 to +660 °C | |
| KTE32AA | Thermocouple temperature sensor calibration in three points in range -40 to +660 °C | |
| KTE52AA | Thermocouple temperature sensor calibration in five points in range -40 to +660 °C | |
| KTE32AB | Thermocouple temperature sensor calibration in three points in range -40 to +1100 °C | |
| KTE52AB | Thermocouple temperature sensor calibration in five points in range -40 to +1100 °C | |
| KTE32B | Thermocouple temperature sensor calibration in three points in range +400 to +1300 °C | |
| KTE52B | Thermocouple temperature sensor calibration in five points in range +400 to +1300 °C | |
| KTE9 | Other | |
| Code | Extended warranty | |
| WE36 | Product warranty 36 months | not for code VR |
| WE__ | Other (the number of months must be added to the code) | not for code VR |
| Code | Accessories | |
| BZS | Stainless steel tag for attachment (70×15 mm) with laser description according to the order | |
| PPZ | Laser description of sensor according to the order | |
| Q1 | Material certificate according to EN 10204, 3.1 | |

Example of order:

T1070 04 F2 J13 L160 H3 S1 D3 N145 P3 KTE31A (-40, 200, 500 °C)

7.3 Ordering table of version without thermowell

Type ① ② ③ ④ ⑤ ⑥ ⑦ ⑧ ⑨ ⑩ ○

| 1. code | Description |
|---------|--|
| T1070 | Resistance temperature sensor without thermowell |
| T1570 | Thermocouple temperature sensor without thermowell |

Temperature sensor ① ② ③ ④ ⑤ ⑥ ⑦ ⑧ ⑨ ⑩ ○

| 2. code | Resistance (RTD) | Sheath material | Max. temperature of use |
|---------|---|-----------------|-------------------------|
| 04 | 1× Pt100, two-wire inside wiring | 1.4404 | up to 500 °C |
| 06 | 1× Pt100, four-wire inside wiring | 1.4404 | up to 600 °C |
| 06HT | 1× Pt100, four-wire inside wiring only for code F7 | Inconel 600 | up to 700 °C |
| 07 | 2× Pt100, three-wire inside wiring | 1.4404 | up to 600 °C |
| 08 | 2× Pt100, two-wire inside wiring | 1.4404 | up to 500 °C |
| 09 | 2× Pt100, four-wire inside wiring only for codes S4 and S5 | 1.4404 | up to 600 °C |

| 2. code | Thermocouple (TC) | Sheath material | Measuring range |
|---------|---|-------------------|-----------------------|
| 20 | 1× "T" (Cu-CuNi), insulated | 1.4541 | -40 (-200) to +350 °C |
| 21 | 1× "J" (Fe-CuNi), insulated | 1.4541 | -40 to +800 °C |
| 61 | 2× "J" (Fe-CuNi), insulated, isolated junctions | 1.4541 | -40 to +800 °C |
| 22 | 1× "K" (NiCr-NiAl), insulated | Inconel 600 | -40 (-200) to 1100 °C |
| 62 | 2× "K" (NiCr-NiAl), insulated, isolated junctions | Inconel 600 | -40 (-200) to 1100 °C |
| 23 | 1× "N" (NiCrSi-NiSi), insulated | Inconel 600 | -40 (-200) to 1100 °C |
| 63 | 2× "N" (NiCrSi-NiSi), insulated, isolated junctions | Inconel 600 | -40 (-200) to 1100 °C |
| 22HT | 1× "K" (NiCr-NiAl), insulated | Nicrobell/Pyrosil | -40 to 1300 °C |
| 62HT | 2× "K" (NiCr-NiAl), insulated, isolated junctions | Nicrobell/Pyrosil | -40 to 1300 °C |
| 23HT | 1× "N" (NiCrSi-NiSi), insulated | Nicrobell/Pyrosil | -40 to 1300 °C |
| 63HT | 2× "N" (NiCrSi-NiSi), insulated, isolated junctions | Nicrobell/Pyrosil | -40 to 1300 °C |
| L U | Grounded version of junction TC | | |
| 99 | Other | | |

Třída přesnosti ① ② ③ ④ ⑤ ⑥ ⑦ ⑧ ⑨ ⑩ ○

| 3. code | Resistance (RTD) according to EN 60751 | Inside wiring material | Measuring range |
|---------|--|------------------------|-----------------|
| F1 | B not for code 06HT | Cu | -50 to +300 °C |
| F2 | B not for code 06HT | Cu | -70 to +500 °C |
| F3 | B only for codes 06, 07 and 09 | Ni *1 | -200 to +600 °C |
| F7 | B only for code 06HT | Ni *1 | -200 to +700 °C |
| F4 | A only for codes 06, 07 and 09 | Cu | -30 to +300 °C |
| F5 | A only for codes 06, 07 and 09 | Cu | -100 to +450 °C |
| F9 | Other | | |

| 3. code | Thermocouple (TC) according to EN 60584-1 | Measuring range |
|---------|---|---|
| T8 | 3 | -200 to +40 °C |
| T7 | 2 | -40 to 350 °C ("T") / 800 °C ("J") / 1200 °C ("K", "N") |
| T6 | 1 not for TC "N" with KV | -40 to 350 °C ("T") / 750 °C ("J") / 1000 °C ("K", "N") |
| T9 | Other | |

*1 – Not allowable to use two-wire connection because of nickel inner wiring.

Fitting of the sensor ① ② ③ ④ ⑤ ⑥ ⑦ ⑧ ⑨ ⑩ ○

| 4. code | Description | Diameter of extension piece | Fitting material |
|---------|--------------------------|-----------------------------|------------------|
| J43 | Without thermowell | 14 × 2,5 mm | 1.4541 |
| J49 | Other without thermowell | | |

Nominal immersion of sensor ① ② ③ ④ ⑤ ⑥ ⑦ ⑧ ⑨ ⑩ ○

| 5. code | Dimension L |
|---------|---|
| L100 | 100 mm |
| L160 | 160 mm |
| L250 | 250 mm |
| L400 | 400 mm |
| L630 | 630 mm |
| L___ | Other (please fill nominal immersion of sensor in mm) |

Head ① ② ③ ④ ⑤ ⑥ ⑦ ⑧ ⑨ ⑩ ○

| 6. code | Description |
|---------|--|
| H1 | Al alloy, cable outlet M20×1.5 for cable Ø 4 to 12.5 mm, IP 65 |
| H2 | Al alloy, cable outlet M20×1.5 for cable Ø 4 to 12.5 mm, IP 65 |
| H3 | Al alloy, with high cap for mounting of transmitter with Ø 44 mm, cable outlet M20×1.5 for cable Ø 4 to 12.5 mm, IP 65 |
| H4N | Al alloy, with low cap, cable outlet M20×1.5 for cable Ø 4 to 12.5 mm, IP 65 |
| H4 | Al alloy, with high cap for mounting of transmitter with Ø 62 mm, cable outlet M20×1.5 for cable Ø 4 to 12.5 mm, IP 65 |
| H5N | Al alloy, with low cap, ground clamps, cable outlet M20×1.5 for cable Ø 5 to 10 m, IP 65 |
| H5 | Al alloy, with high cap for mounting of transmitter with Ø 62 mm, ground clamps, cable outlet M20×1.5 for cable Ø 5 to 10 mm, IP 65 |
| H5PA | Polyamide, with high cap for mounting of transmitter with Ø 62 mm, Tmax 80 °C, cable outlet M20×1.5 for cable Ø 4 to 12.5 mm, IP 65 |
| H6 | Al alloy, ground clamps, thread for cable outlet M20×1.5, IP 68 |
| H7 | Stainless steel, ground clamps, thread for cable outlet M20×1.5, IP 68 |
| H11 | Al alloy, screw cap with chain, without cable gland, ground clamps, IP68 |
| H12 | Stainless steel AISI316, screw cap with chain, without cable gland, ground clamps, IP68 |
| H13 | Al alloy, screw cap with peephole, without cable gland, IP68 |
| H14 | Stainless steel AISI316, screw cap with peephole, without cable gland, IP68 |
| L D | Double cable outlet only for codes H4, H4N, H5, H5N |
| L W | Sensor head with peephole for display only for codes H4 Z1, H4D Z1, H5 Z1E a S2; ne pro dvojité čidla |
| H9 | Other |

Cold-end of measuring insert ① ② ③ ④ ⑤ ⑥ ⑦ ⑧ ⑨ ⑩ ○

| 7. code | Description |
|---------|---|
| S1 | With ceramic terminal block (diameter 42 mm) on flange of measuring insert <i>only for diameter 6 mm (code D3)</i> |
| S2 | For single sensor, without terminal block, with set for mounting of transmitter on flange of measuring insert (instead of terminal block) |
| S4 | For double sensor, without terminal block, with set for mounting of two transmitters <i>not suitable for H1, H2, H5N, H6 and H7</i> |
| S5 | With ceramic terminal block (diameter 42 mm), embedded pins (according to NAMUR) |
| S9 | Other |

Measuring insert diameter ① ② ③ ④ ⑤ ⑥ ⑦ ⑧ ⑨ ⑩ ○

| 8. code | Description |
|---------|---|
| D1 | 3 mm |
| D2 | 4,5 mm only for TC |
| D3 | 6 mm |
| D9 | Other |

Extension piece ① ② ③ ④ ⑤ ⑥ ⑦ ⑧ ⑨ ⑩ ○

| 9. code | Nominal length of extension piece – N | Max. temperature of connection thread |
|---------|---|---------------------------------------|
| N145 | With extension piece N=145 mm | 600 °C |
| N___ | Other (please fill nominal length of extension piece in mm) | |

| Process connection | | ① ② ③ ④ ⑤ ⑥ ⑦ ⑧ ⑨ ⑩ |
|--|--|--|
| 10. code | Description | |
| P3 | Male thread M20×1,5 | |
| P5 | Male thread G1/2" | |
| P7 | Male thread 1/2"NPT | |
| P9 | Other | |
| Optional accessories | | ① ② ③ ④ ⑤ ⑥ ⑦ ⑧ ⑨ ⑩ ● |
| Code | Versions for explosive atmosphere of gasses or dusts | |
| EI | (Ex) II 1/2G Ex ia IIC T6...Tx°C Ga/Gb, (Ex) II 1/2D Ex ia IIIC T ₂₀₀ 85°C...T ₂₀₀ x°C Da/Db | only for heads H5, H5N, H6, H7, H11, H12, H13, H14 |
| Code | Indication units | |
| Z1 | LED display mounted in sensor head only for code H4(D)W and S2, S3; operating temperature -20 to +80 °C | |
| Z1E | Intrinsically safe LED display in sensor head (Ex) II 2G Ex ia IIC T6 only for codes H5W and S2, S3; operating temperature -20 to +80 °C | |
| Code | Cable outlet *1 | |
| KM1 | Cable outlet, nickel-plated brass, IP 68, M20×1.5, for cable Ø 5 to 10 mm standard for H6, H7 | |
| KM4 | Cable outlet, stainless steel, IP 68, M20×1.5, for cable Ø 7 to 12 mm | |
| KME1 | Cable outlet, nickel-plated brass, Ex d, M20×1.5, IP 68, for fixed assembly cable Ø 4.5 to 8.5 mm | |
| KME2 | Cable outlet, nickel-plated brass, Ex d, M20×1.5, IP 68, for fixed assembly cable Ø 7 to 12 mm | |
| KME3 | Cable outlet, stainless steel, Ex d, M20×1.5, IP 68, for fixed assembly cable Ø 4 to 8 mm | |
| KME5 | Cable outlet, polyamide (light blue), Ex e, M20×1.5, IP 68, for fixed assembly cable Ø 5 to 9 mm, operating temperature -20 to +95 °C not for H5PA | |
| KME6 | Cable outlet, polyamide (light blue), Ex e, M20×1.5, IP 68, for fixed assembly cable Ø 6.5 to 12 mm, operating temperature -20 to +95 °C not for H5PA | |
| KM9 | Other | |
| PK1 | Lock anti pull-up cable for Ex d cable outlet KME1 | |
| PK2 | Lock anti pull-up cable for Ex d cable outlet KME2 | |
| *1 - The heads H1, H2, H3, H4, H4N, H5, H5N are usually equipped with nickel-plated brass cable outlet for cable with diameter 4 to 12.5 mm. | | |
| Code | Snap lock | |
| RU | Snap lock | only with codes H2, H4, H4N, H5, H5N |
| Code | Calibration in customer defined points, including certificate of calibration | |
| KTE31A | Resistance temperature sensor calibration in three points in range -40 to +660 °C | |
| KTE51A | Resistance temperature sensor calibration in five points in range -40 to +660 °C | |
| KTE32AA | Thermocouple temperature sensor calibration in three points in range -40 to +660 °C | |
| KTE52AA | Thermocouple temperature sensor calibration in five points in range -40 to +660 °C | |
| KTE32AB | Thermocouple temperature sensor calibration in three points in range -40 to +1100 °C | |
| KTE52AB | Thermocouple temperature sensor calibration in five points in range -40 to +1100 °C | |
| KTE32B | Thermocouple temperature sensor calibration in three points in range +400 to +1300 °C | |
| KTE52B | Thermocouple temperature sensor calibration in five points in range +400 to +1300 °C | |
| KTE9 | Other | |
| Code | Extended warranty | |
| WE36 | Product warranty 36 months | not for code VR |
| WE__ | Other (the number of months must be added to the code) | not for code VR |
| Code | Accessories | |
| BZS | Stainless steel tag for attachment (70×15 mm) with laser description according to the order | |
| PPZ | Laser description of sensor according to the order | |
| Q1 | Material certificate according to EN 10204, 3.1 | |

Example of order:

T1070 04 F2 J43 L160 H3 S1 D3 N145 P3 KTE31A (-40, 200, 500 °C)

7.4 Ordering table of version without fitting

| Type | | ① ② ③ ④ ⑤ ⑥ ⑦ ⑧ ○ | | | | | | | |
|---------|---|-------------------|--|--|--|--|--|--|--|
| 1. code | Description | | | | | | | | |
| T1070 | Resistance temperature sensor without fitting | | | | | | | | |
| T1570 | Thermocouple temperature sensor without fitting | | | | | | | | |

| Temperature sensor | | | | ① ② ③ ④ ⑤ ⑥ ⑦ ⑧ ○ | | | | | | | |
|--------------------|---|-------------------|-------------------------|-------------------|--|--|--|--|--|--|--|
| 2. code | Resistance (RTD) | Sheath material | Max. temperature of use | | | | | | | | |
| 04 | 1× Pt100, two-wire inside wiring | 1.4404 | up to 500 °C | | | | | | | | |
| 06 | 1× Pt100, four-wire inside wiring | 1.4404 | up to 600 °C | | | | | | | | |
| 06HT | 1× Pt100, four-wire inside wiring only for code F7 | Inconel 600 | up to 700 °C | | | | | | | | |
| 07 | 2× Pt100, three-wire inside wiring | 1.4404 | up to 600 °C | | | | | | | | |
| 08 | 2× Pt100, two-wire inside wiring | 1.4404 | up to 500 °C | | | | | | | | |
| 09 | 2× Pt100, four-wire inside wiring only for codes S4 and S5 | 1.4404 | up to 600 °C | | | | | | | | |
| L VR | Increased resistance to vibration and shock only for code 06 F2 ... S5 | | | | | | | | | | |
| 2. code | Thermocouple (TC) | Sheath material | Measuring range | | | | | | | | |
| 20 | 1× "T" (Cu-CuNi), insulated | 1.4541 | -40 (-200) to +350 °C | | | | | | | | |
| 21 | 1× "J" (Fe-CuNi), insulated | 1.4541 | -40 to +800 °C | | | | | | | | |
| 61 | 2× "J" (Fe-CuNi), insulated, isolated junctions | 1.4541 | -40 to +800 °C | | | | | | | | |
| 22 | 1× "K" (NiCr-NiAl), insulated | Inconel 600 | -40 (-200) to 1100 °C | | | | | | | | |
| 62 | 2× "K" (NiCr-NiAl), insulated, isolated junctions | Inconel 600 | -40 (-200) to 1100 °C | | | | | | | | |
| 23 | 1× "N" (NiCrSi-NiSi), insulated | Inconel 600 | -40 (-200) to 1100 °C | | | | | | | | |
| 63 | 2× "N" (NiCrSi-NiSi), insulated, isolated junctions | Inconel 600 | -40 (-200) to 1100 °C | | | | | | | | |
| 22HT | 1× "K" (NiCr-NiAl), insulated | Nicrobell/Pyrosil | -40 to 1300 °C | | | | | | | | |
| 62HT | 2× "K" (NiCr-NiAl), insulated, isolated junctions | Nicrobell/Pyrosil | -40 to 1300 °C | | | | | | | | |
| 23HT | 1× "N" (NiCrSi-NiSi), insulated | Nicrobell/Pyrosil | -40 to 1300 °C | | | | | | | | |
| 63HT | 2× "N" (NiCrSi-NiSi), insulated, isolated junctions | Nicrobell/Pyrosil | -40 to 1300 °C | | | | | | | | |
| L U | Grounded version of junction TC | | | | | | | | | | |
| 99 | Other | | | | | | | | | | |

| Accuracy class | | | | ① ② ③ ④ ⑤ ⑥ ⑦ ⑧ ○ | | | | | | | |
|----------------|---|---|-----------------|-------------------|--|--|--|--|--|--|--|
| 3. code | Resistance (RTD) according to EN 60751 | Inside wiring material | Measuring range | | | | | | | | |
| F1 | B not for code 06HT | Cu | -50 to +300 °C | | | | | | | | |
| F2 | B not for code 06HT | Cu | -70 to +500 °C | | | | | | | | |
| F3 | B only for codes 06, 07 and 09 | Ni *1 | -200 to +600 °C | | | | | | | | |
| F7 | B only for code 06HT | Ni *1 | -200 to +700 °C | | | | | | | | |
| F4 | A only for codes 06, 07 and 09 | Cu | -30 to +300 °C | | | | | | | | |
| F5 | A only for codes 06, 07 and 09 | Cu | -100 to +450 °C | | | | | | | | |
| F9 | Other | | | | | | | | | | |
| 3. code | Thermocouple (TC) according to EN 60584-1 | Measuring range | | | | | | | | | |
| T8 | 3 | -200 to +40 °C | | | | | | | | | |
| T7 | 2 | -40 to 350 °C ("T") / 800 °C ("J") / 1200 °C ("K", "N") | | | | | | | | | |
| T6 | 1 not for TC "N" with KV | -40 to 350 °C ("T") / 750 °C ("J") / 1000 °C ("K", "N") | | | | | | | | | |
| T9 | Other | | | | | | | | | | |

*1 - Not allowable to use two-wire connection because of nickel inner wiring.

Fitting of the sensor

1 2 3 4 5 6 7 8

| 4. code | Description |
|---------|---|
| B00 | Without fitting |
| B01 | Without fitting, with SST thermometer holder for wallmounting Standard for heads H4, H5, H6 and H7; it is possible to use for heads H1, H2 and H3, but the version B00 with holder DH1 is cheaper. |
| B99 | Other without fitting |

Nominal length

1 2 3 4 5 6 7 8

| 5. code | Dimension L |
|---------|---|
| L115 | 115 mm |
| L175 | 175 mm |
| L245 | 245 mm |
| L305 | 305 mm |
| L335 | 335 mm |
| L395 | 395 mm |
| L500 | 500 mm |
| L545 | 545 mm |
| L710 | 710 mm |
| L775 | 775 mm |
| L800 | 800 mm |
| L1000 | 1000 mm |
| L1400 | 1400 mm |
| L2000 | 2000 mm |
| L____ | Other (please fill in nominal length in mm) |

Head

1 2 3 4 5 6 7 8

| 6. code | Description |
|---------|---|
| H1 | Al alloy, cable outlet M20×1.5 for cable Ø 4 to 12.5 mm, IP 65 |
| H2 | Al alloy, cable outlet M20×1.5 for cable Ø 4 to 12.5 mm, IP 65 |
| H3 | Al alloy, with high cap for mounting of transmitter with Ø 44 mm, cable outlet M20×1.5 for cable Ø 4 to 12.5 mm, IP 65 |
| H4N | Al alloy, with low cap, cable outlet M20×1.5 for cable Ø 4 to 12.5 mm, IP 65 |
| H4 | Al alloy, with high cap for mounting of transmitter with Ø 62 mm, cable outlet M20×1.5 for cable Ø 4 to 12.5 mm, IP 65 |
| H5N | Al alloy, with low cap, ground clamps, cable outlet M20×1.5 for cable Ø 5 to 10 mm, IP 65 |
| H5 | Al alloy, with high cap for mounting of transmitter with Ø 62 mm, ground clamps, cable outlet M20×1.5 for cable Ø 5 to 10 mm, IP 65 |
| H5PA | Polyamide, with high cap for mounting of transmitter with Ø 62 mm, Tmax 80 °C, cable outlet M20×1.5 for cable Ø 4 to 12.5 mm, IP 65 |
| H6 | Al alloy, ground clamps, thread for cable outlet M20×1.5, IP 68 |
| H7 | Stainless steel, ground clamps, thread for cable outlet M20×1.5, IP 68 |
| H11 | Al alloy, screw cap with chain, without cable gland, ground clamps, IP68 |
| H12 | Stainless steel AISI316, screw cap with chain, without cable gland, ground clamps, IP68 |
| H13 | Al alloy, screw cap with peephole, without cable gland, IP68 |
| H14 | Stainless steel AISI316, screw cap with peephole, without cable gland, IP68 |
| L D | Double cable outlet only for codes H4, H4N, H5, H5N |
| L W | Sensor head with peephole for display only for codes H4 Z1, H4D Z1, H5 Z1E a S2; ne pro dvojité čidla |
| H9 | Other |

Cold-end of measuring insert

1 2 3 4 5 6 7 8

| 7. code | Description |
|---------|--|
| S1 | With ceramic terminal block (diameter 42 mm) on flange of measuring insert only for diameter 6 mm (code D3, D5) |

| 7. code | Description |
|---------|---|
| S2 | For single sensor, without terminal block, with set for mounting of transmitter on flange of measuring insert (instead of terminal block) |
| S4 | For double sensor, without terminal block, with set for mounting of two transmitters not suitable for H1, H2, H5N, H6 and H7 |
| S5 | With ceramic terminal block (diameter 42 mm), embedded pins (according to NAMUR) |
| S9 | Other |

Measuring insert diameter ① ② ③ ④ ⑤ ⑥ ⑦ ⑧ ○

| 8. code | Description |
|---------|---|
| D1 | 3 mm |
| D2 | 4,5 mm only for TC |
| D3 | 6 mm |
| D5 | 6 mm with distance sleeve 8 mm |
| D9 | Other |

Optional accessories ① ② ③ ④ ⑤ ⑥ ⑦ ⑧ ●

| Code | Versions for explosive atmosphere of gasses or dusts |
|------|---|
| EI | (Ex) II 1/2G Ex ia IIC T6...Tx°C Ga/Gb, only for heads H5, H5N, H6, H7, H11, H12, H13, H14 (Ex) II 1/2D Ex ia IIIC T ₂₀₀ 85°C...T ₂₀₀ x°C Da/Db |

| Code | Indication units |
|------|---|
| Z1 | LED display mounted in sensor head only for code H4(D)W and S2, S3; operating temperature -20 to +80 °C |
| Z1E | Intrinsically safe LED display in sensor head (Ex) II 2G Ex ia IIC T6 only for codes H5W and S2, S3; operating temperature -20 to +80 °C |

| Code | Cable outlet *1 |
|------|--|
| KM1 | Cable outlet, nickel-plated brass, IP 68, M20×1.5, for cable Ø 5 to 10 mm standard for H6, H7 |
| KM4 | Cable outlet, stainless steel, IP 68, M20×1.5, for cable Ø 7 to 12 mm |
| KME1 | Cable outlet, nickel-plated brass, Ex d, M20×1.5, IP 68, for fixed assembly cable Ø 4.5 to 8.5 mm |
| KME2 | Cable outlet, nickel-plated brass, Ex d, M20×1.5, IP 68, for fixed assembly cable Ø 7 to 12 mm |
| KME3 | Cable outlet, stainless steel, Ex d, M20×1.5, IP 68, for fixed assembly cable Ø 4 to 8 mm |
| KME5 | Cable outlet, polyamide (light blue), Ex e, M20×1.5, IP 68, for fixed assembly cable Ø 5 to 9 mm, operating temperature -20 to +95 °C not for H5PA |
| KME6 | Cable outlet, polyamide (light blue), Ex e, M20×1.5, IP 68, for fixed assembly cable Ø 6.5 to 12 mm, operating temperature -20 to +95 °C not for H5PA |
| KM9 | Other |
| PK1 | Lock anti pull-up cable for Ex d cable outlet KME1 |
| PK2 | Lock anti pull-up cable for Ex d cable outlet KME2 |

*1 – The heads H1, H2, H3, H4, H4N, H5, H5N are usually equipped with nickel-plated brass cable outlet for cable with diameter 4 to 12.5 mm.

| Code | Holder, Snap lock |
|------|---|
| DH1 | Holder for wall-mounting optional only for code B00 with head H1, H2, H3 |
| RU | Snap lock only with codes H2, H4, H4N, H5, H5N |

| Code | Calibration in customer defined points, including certificate of calibration |
|---------|---|
| KTE31A | Resistance temperature sensor calibration in three points in range -40 to +660 °C |
| KTE51A | Resistance temperature sensor calibration in five points in range -40 to +660 °C |
| KTE32AA | Thermocouple temperature sensor calibration in three points in range -40 to +660 °C |
| KTE52AA | Thermocouple temperature sensor calibration in five points in range -40 to +660 °C |
| KTE32AB | Thermocouple temperature sensor calibration in three points in range -40 to +1100 °C |
| KTE52AB | Thermocouple temperature sensor calibration in five points in range -40 to +1100 °C |
| KTE32B | Thermocouple temperature sensor calibration in three points in range +400 to +1300 °C |
| KTE52B | Thermocouple temperature sensor calibration in five points in range +400 to +1300 °C |
| KTE9 | Other |

| Code | Extended warranty | |
|------------------|---|-----------------|
| WE36 | Product warranty 36 months | not for code VR |
| WE__ | Other (the number of months must be added to the code) | not for code VR |
| Code | Accessories | |
| BZS | Stainless steel tag for attachment (70×15 mm) with laser description according to the order | |
| PPZ | Laser description of sensor according to the order | |
| Code | Fixing shift pipe unions | |
| UPS3M12 | Fixing shift pipe union for diameter 3 mm, connecting thread M12×1.5 *1 | |
| UPS4,5M12 | Fixing shift pipe union for diameter 4.5 mm, connecting thread M12×1.5 *1 | |
| UPS6M20 | Fixing shift pipe union for diameter 6 mm, connecting thread M20×1.5 *1 | |

*1 - It is suitable only for non-flowing gas medium, free of mechanical stress including impacts and vibrations, where adjustable nominal length is required and it is impossible to use fixing pipe unions PT because of high temperature.

Example of order:

T1070 04 F2 J13 L160 H3 S1 D3 N145 P3 KTE31A (-40, 200, 500 °C)

Fixing shift pipe union for sheath temperature sensor

| Version P 1 2 3 | | | |
|--|--|------------------|------------------|
| 1. code | Description | T _{MAX} | p _{MAX} |
| S | With stainless steel cutting ring, pipe union of stainless steel material *1 | 600 °C / 0,1 MPa | 4 MPa / 100 °C |
| T | With PTFE sealing ring, pipe union of stainless steel material *2 | 200 °C / 0,1 MPa | 0,6 MPa / 100 °C |

*1 - Adjustable nominal length only for first time of mounting.. *2 - Always adjustable nominal length.

| Connection thread Z P 1 2 3 | | |
|--|-------------|----------------------------------|
| 2. code | Description | For sensors with diameter sheath |
| M01 | M8×1 | 1 až 3 mm |
| M02 | M12×1,5 | 3 až 6 mm |
| M03 | M16×1,5 | 3 až 6 mm |
| M04 | M20×1,5 | 3 až 6 mm |
| G01 | G1/8" | 1 až 3 mm |
| G02 | G1/4" | 3 až 6 mm |
| G03 | G3/8" | 3 až 6 mm |
| G04 | G1/2" | 3 až 6 mm |
| N01 | 1/8" NPT | 1 až 3 mm |
| N02 | 1/4" NPT | 3 až 6 mm |
| N03 | 3/8" NPT | 3 až 6 mm |
| N04 | 1/2" NPT | 3 až 6 mm |

| Outer diameter of stem sensor P 1 2 3 | |
|--|-------------|
| 3. code | Description |
| D30 | 3 mm |
| D45 | 4,5 mm |
| D60 | 6 mm |

Example of order:

PS M04 D30

7.5 Ordering table of straight version

| Type | | 1 2 3 4 5 6 7 ○ | | | | | | |
|---|---|---|-------------------------|--|--|--|--|--|
| 1. code | Description | | | | | | | |
| T1070 | Straight resistance temperature sensor | | | | | | | |
| T1570 | Straight thermocouple temperature sensor | | | | | | | |
| Temperature sensor | | 1 2 3 4 5 6 7 ○ | | | | | | |
| 2. code | Resistance (RTD) | Sheath material | Max. temperature of use | | | | | |
| 04 | 1× Pt100, two-wire inside wiring | 1.4404 | up to 500 °C | | | | | |
| 06 | 1× Pt100, four-wire inside wiring | 1.4404 | up to 600 °C | | | | | |
| 06HT | 1× Pt100, four-wire inside wiring only for code F7 | Inconel 600 | up to 700 °C | | | | | |
| 07 | 2× Pt100, three-wire inside wiring | 1.4404 | up to 600 °C | | | | | |
| 08 | 2× Pt100, two-wire inside wiring | 1.4404 | up to 500 °C | | | | | |
| 09 | 2× Pt100, four-wire inside wiring only for codes S4 and S5 | 1.4404 | up to 600 °C | | | | | |
| L VR | Increased resistance to vibration and shock only for code 06 F2 ... S5 | | | | | | | |
| 2. code | Thermocouple (TC) | Sheath material | Measuring range | | | | | |
| 20 | 1× "T" (Cu-CuNi), insulated | 1.4541 | -40 (-200) to +350 °C | | | | | |
| 21 | 1× "J" (Fe-CuNi), insulated | 1.4541 | -40 to +800 °C | | | | | |
| 61 | 2× "J" (Fe-CuNi), insulated, isolated junctions | 1.4541 | -40 to +800 °C | | | | | |
| 22 | 1× "K" (NiCr-NiAl), insulated | Inconel 600 | -40 (-200) to 1100 °C | | | | | |
| 62 | 2× "K" (NiCr-NiAl), insulated, isolated junctions | Inconel 600 | -40 (-200) to 1100 °C | | | | | |
| 23 | 1× "N" (NiCrSi-NiSi), insulated | Inconel 600 | -40 (-200) to 1100 °C | | | | | |
| 63 | 2× "N" (NiCrSi-NiSi), insulated, isolated junctions | Inconel 600 | -40 (-200) to 1100 °C | | | | | |
| 22HT | 1× "K" (NiCr-NiAl), insulated | Nicrobell/Pyrosil | -40 to 1300 °C | | | | | |
| 62HT | 2× "K" (NiCr-NiAl), insulated, isolated junctions | Nicrobell/Pyrosil | -40 to 1300 °C | | | | | |
| 23HT | 1× "N" (NiCrSi-NiSi), insulated | Nicrobell/Pyrosil | -40 to 1300 °C | | | | | |
| 63HT | 2× "N" (NiCrSi-NiSi), insulated, isolated junctions | Nicrobell/Pyrosil | -40 to 1300 °C | | | | | |
| L U | Grounded version of junction TC | | | | | | | |
| 99 | Other | | | | | | | |
| Accuracy class | | 1 2 3 4 5 6 7 ○ | | | | | | |
| 3. code | Resistance (RTD) according to EN 60751 | Inside wiring material | Measuring range | | | | | |
| F1 | B not for code 06HT | Cu | -50 to +300 °C | | | | | |
| F2 | B not for code 06HT | Cu | -70 to +500 °C | | | | | |
| F3 | B only for codes 06, 07 and 09 | Ni *1 | -200 to +600 °C | | | | | |
| F7 | B only for code 06HT | Ni *1 | -200 to +700 °C | | | | | |
| F4 | A only for codes 06, 07 and 09 | Cu | -30 to +300 °C | | | | | |
| F5 | A only for codes 06, 07 and 09 | Cu | -100 to +450 °C | | | | | |
| F9 | Other | | | | | | | |
| 3. code | Thermocouple (TC) according to EN 60584-1 | Measuring range | | | | | | |
| T8 | 3 | -200 to +40 °C | | | | | | |
| T7 | 2 | -40 to 350 °C ("T") / 800 °C ("J") / 1200 °C ("K", "N") | | | | | | |
| T6 | 1 not for TC "N" with KV | -40 to 350 °C ("T") / 750 °C ("J") / 1000 °C ("K", "N") | | | | | | |
| T9 | Other | | | | | | | |
| *1 - Not allowable to use two-wire connection because of nickel inner wiring. | | | | | | | | |
| Fitting of the sensor | | 1 2 3 4 5 6 7 ○ | | | | | | |
| 4. code | Straight sensor with protective tube | Fitting material | T _{MAX} | | | | | |
| B53 | Ø 11 × 2 mm | 1.4541 | up to 800 °C | | | | | |

| 4. code | Straight sensor with protective tube | Fitting material | T _{MAX} |
|-------------|---|------------------|------------------|
| B63 | Ø 14 × 2,5 mm | 1.4541 | up to 800 °C |
| B64 | Ø 14 × 2,5 mm | 1.4845 | up to 1100 °C |
| B66 | Ø 15 × 1,3 mm only for code ... HT, H4 ... H5 | Kanthal AF | up to 1300 °C |
| B73 | Ø 20 × 3 mm | 1.4541 | up to 800 °C |
| B74 | Ø 20 × 3 mm | 1.4845 | up to 1100 °C |
| B83 | Ø 22 × 2 mm | 1.4541 | up to 800 °C |
| B84 | Ø 22 × 2 mm | 1.4845 | up to 1100 °C |
| B85 | Ø 22 × 2 mm | 1.4762 | up to 1100 °C |
| B86 | Ø 22 × 1,3 mm only for code ... HT | Kanthal AF | up to 1300 °C |
| L C | Inner ceramic protective tube Ø 15 mm of C610 only for tubes 22×2 mm and 22×1.3 mm and heads HA, HAN, not for S8 | | |
| B84Z | Ø 22 × 3,5 mm | 1.4845 | up to 1100 °C |
| B842 | Ø 22 × 7,5 mm in length 200 mm, then 22 x 2 mm | 1.4845 | up to 1100 °C |
| B843 | Ø 22 × 7,5 mm in length 300 mm, then 22 x 2 mm | 1.4845 | up to 1100 °C |
| B852 | Ø 22 × 7,5 mm in length 200 mm, then 22 x 2 mm | 1.4762 | up to 1100 °C |
| B853 | Ø 22 × 7,5 mm in length 300 mm, then 22 x 2 mm | 1.4762 | up to 1100 °C |
| B99 | Other straight | | |

Nominal length

① ② ③ ④ ⑤ ⑥ ⑦ ○

| 5. code | Dimension L |
|---------------|--|
| L180 | 180 mm |
| L250 | 250 mm |
| L310 | 310 mm |
| L400 | 400 mm |
| L500 | 500 mm |
| L600 | 600 mm |
| L710 | 710 mm |
| L800 | 800 mm |
| L1000 | 1000 mm |
| L1200 | 1200 mm |
| L1400 | 1400 mm |
| L1600 | 1600 mm |
| L2000 | 2000 mm |
| L_____ | Other (please fill nominal length in mm) |

Head

① ② ③ ④ ⑤ ⑥ ⑦ ○

| 6. code | Description |
|-------------|---|
| H1 | Al alloy, cable outlet M20×1.5 for cable Ø 4 to 12.5 mm, IP 65 |
| H2 | Al alloy, cable outlet M20×1.5 for cable Ø 4 to 12.5 mm, IP 65 |
| H3 | Al alloy, with high cap for mounting of transmitter with Ø 44 mm, cable outlet M20×1.5 for cable Ø 4 to 12.5 mm, IP 65 |
| H4N | Al alloy, with low cap, cable outlet M20×1.5 for cable Ø 4 to 12.5 mm, IP 65 |
| H4 | Al alloy, with high cap for mounting of transmitter with Ø 62 mm, cable outlet M20×1.5 for cable Ø 4 to 12.5 mm, IP 65 |
| H5N | Al alloy, with low cap, ground clamps, cable outlet M20×1.5 for cable Ø 5 to 10 mm, IP 65 |
| H5 | Al alloy, with high cap for mounting of transmitter with Ø 62 mm, ground clamps, cable outlet M20×1.5 for cable Ø 5 to 10 mm, IP 65 |
| H5PA | Polyamide, with high cap for mounting of transmitter with Ø 62 mm, Tmax 80 °C, cable outlet M20×1.5 for cable Ø 4 to 12.5 mm, IP 65 |
| H6 | Al alloy, ground clamps, thread for cable outlet M20×1.5, IP 68 |

| 6. code | Description |
|---------|--|
| H7 | Stainless steel, ground clamps, thread for cable outlet M20×1.5, IP 68 |
| H11 | Al alloy, screw cap with chain, without cable gland, ground clamps, IP68 |
| H12 | Stainless steel AISI316, screw cap with chain, without cable gland, ground clamps, IP68 |
| H13 | Al alloy, screw cap with peephole, without cable gland, IP68 |
| H14 | Stainless steel AISI316, screw cap with peephole, without cable gland, IP68 |
| L D | Double cable outlet only for codes H4, H4N, H5, H5N |
| L W | Sensor head with peephole for display only for codes H4 Z1, H4D Z1, H5 Z1E a S2; ne pro dvojité čidla |
| H9 | Other |

Cold-end of measuring insert

| 7. code | Description |
|---------|--|
| S1 | With ceramic terminal block (diameter 42 mm) on flange of measuring insert |
| S2 | For single sensor, without terminal block, with set for mounting of transmitter on flange of measuring insert (instead of terminal block) |
| S4 | For double sensor, without terminal block, with set for mounting of two transmitters <small>not suitable for H1, H2, H5N, H6 and H7</small> |
| S5 | With ceramic terminal block (diameter 42 mm), embedded pins (according to NAMUR) |
| S8 | With ceramic terminal block (diameter 55 mm), with hole for insertion of control sensor <small>only for HA, HAN</small> |
| S9 | Other |

Optional accessories

| Code | Versions for explosive atmosphere of gasses or dusts | |
|-------|---|--|
| | Flameproof enclosure "Ex d" only for gasses and protection by enclosure "Ex t" only for dusts, intrinsically safe version "Ex i" for gasses and dusts | |
| ED/ET | (Ex) II 1/2G Ex db IIC T6...Tx°C Ga/Gb, (Ex) II 1/2D Ex ta/tb IIIC T90°C...Tx°C Da/Db only for heads H6, H7, H11, H12, H13, H14 | |
| EI | (Ex) II 1/2G Ex ia IIC T6...Tx°C Ga/Gb, (Ex) II 1/2D Ex ia IIIC T ₂₀₀ 85°C...T ₂₀₀ x°C Da/Db only for heads H5, H5N, H6, H7, H11, H12, H13, H14 | |
| ET | (Ex) II 1/2D Ex ta/tb IIIC T90°C...Tx°C Da/Db only for heads H5, H5N | |
| Code | Protective spray | T _{MAX} (with spray) |
| X01 | polyamid PA11 | 100 °C *1 |
| X02 | ethylen-chlorotrifluorethylen E-CTFE "Halar" | 170 °C *1 |
| X03 | perfluoralkoxy - kopolymer tetrafluorethylenu a perfluorovaného vinylé-theru PFA | 260 °C *1 |
| X04 | ethylentetrafluorethylen ETFE "Hyflon" | 130 °C *1 |
| X05 | polytetrafluorethylen PTFE | 260 °C *1 |
| X07 | Hard metal coating (Fe-Cr-Mn-Si-B-C) for abrasive medium | 925 °C |
| X08 | Corundum spray for intense abrasive medium | according to specific composition of coating |
| X99 | Other | |

*1 - Depends on measured medium.

| Code | Indication units |
|------|--|
| Z1 | LED display mounted in sensor head <small>only for code H4(D)W and S2, S3; operating temperature -20 to +80 °C</small> |
| Z1E | Intrinsically safe LED display in sensor head (Ex) II 2G Ex ia IIC T6 <small>only for codes H5W and S2, S3; operating temperature -20 to +80 °C</small> |

| Code | Cable outlet *1 |
|------|---|
| KM1 | Cable outlet, nickel-plated brass, IP 68, M20×1.5, for cable Ø 5 to 10 mm <small>standard for H6, H7</small> |
| KM4 | Cable outlet, stainless steel, IP 68, M20×1.5, for cable Ø 7 to 12 mm |
| KME1 | Cable outlet, nickel-plated brass, Ex d, M20×1.5, IP 68, for fixed assembly cable Ø 4.5 to 8.5 mm |
| KME2 | Cable outlet, nickel-plated brass, Ex d, M20×1.5, IP 68, for fixed assembly cable Ø 7 to 12 mm |
| KME3 | Cable outlet, stainless steel, Ex d, M20×1.5, IP 68, for fixed assembly cable Ø 4 to 8 mm |

| Code | Cable outlet *1 |
|------|--|
| KME5 | Cable outlet, polyamide (light blue), Ex e, M20×1.5, IP 68, for fixed assembly cable Ø 5 to 9 mm, operating temperature -20 to +95 °C not for H5PA |
| KME6 | Cable outlet, polyamide (light blue), Ex e, M20×1.5, IP 68, for fixed assembly cable Ø 6.5 to 12 mm, operating temperature -20 to +95 °C not for H5PA |
| KM9 | Other |
| PK1 | Lock anti pull-up cable for Ex d cable outlet KME1 |
| PK2 | Lock anti pull-up cable for Ex d cable outlet KME2 |

*1 – The heads H1, H2, H3, H4, H4N, H5, H5N are usually equipped with nickel-plated brass cable outlet for cable with diameter 4 to 12.5 mm.

| Code | Snap lock |
|------|---|
| RU | Snap lock only with codes H2, H4, H4N, H5, H5N |

| Code | Calibration in customer defined points, including certificate of calibration |
|---------|---|
| KTE31A | Resistance temperature sensor calibration in three points in range -40 to +660 °C |
| KTE51A | Resistance temperature sensor calibration in five points in range -40 to +660 °C |
| KTE32AB | Thermocouple temperature sensor calibration in three points in range -40 to +1100 °C |
| KTE52AB | Thermocouple temperature sensor calibration in five points in range -40 to +1100 °C |
| KTE32B | Thermocouple temperature sensor calibration in three points in range +400 to +1300 °C |
| KTE52B | Thermocouple temperature sensor calibration in five points in range +400 to +1300 °C |
| KTE9 | Other |

| Code | Extended warranty |
|------|---|
| WE36 | Product warranty 36 months not for code VR |
| WE__ | Other (the number of months must be added to the code) not for code VR |

| Code | Accessories |
|------|---|
| BZS | Stainless steel tag for attachment (70×15 mm) with laser description according to the order |
| PPZ | Laser description of sensor according to the order |
| Q1 | Material certificate according to EN 10204, 3.1 |

| Code | Fixing shift pipe unions and flanges *1 |
|----------|---|
| UPS11M20 | Fixing shift pipe union for diameter 11 mm, connecting thread M20×1,5 |
| UPS14M27 | Fixing shift pipe union for diameter 14 mm, connecting thread M27×2 |
| UPS15M27 | Fixing shift pipe union for diameter 15 mm, connecting thread M27×2 |
| UPS20M30 | Fixing shift pipe union for diameter 20 mm, connecting thread M30×2 |
| UPS22M33 | Fixing shift pipe union for diameter 22 mm, connecting thread M33×2 |
| UP01 | Fixing shift flange for diameter 14 mm |
| UP02 | Fixing shift flange for diameter 15 mm |
| UP03 | Fixing shift flange for diameter 22 mm |
| P9 | Other |

*1 – It is suitable only for non-flowing gas medium, free of mechanical stress including impacts and vibrations, where adjustable nominal length is required and it is impossible to use fixing pipe unions PT because of high temperature.

Example of order:

T1070 04 F2 B53 L310 H3 S1 KTE31A (-40, 200, 500 °C)

7.6 Ordering table of spatial version for explosive atmosphere of gasses or dusts

Type 1 2 3 4 5 6 7 8 9

| 1. code | Description |
|---------|--|
| T1070 | Spatial resistance temperature sensor for explosive atmosphere |

Temperature sensor 1 2 3 4 5 6 7 8 9

| 2. code | Resistance (RTD) | Sheath material |
|---------|--------------------------------|-----------------|
| 04 | 1× Pt100, 2-wire inside wiring | 1.4404 |
| 06 | 1× Pt100, 4-wire inside wiring | 1.4404 |
| 07 | 2× Pt100, 3-wire inside wiring | 1.4404 |
| 08 | 2× Pt100, 2-wire inside wiring | 1.4404 |
| 09 | Other | |

Accuracy class 1 2 3 4 5 6 7 8 9

| 3. code | Resistance (RTD) according to EN 60751 | Inside wiring material | Measuring range |
|---------|--|------------------------|-------------------------------------|
| F1 | B | Cu | -50 to +100 °C 85 °C for code ED |
| F4 | A | Cu | -30 to +100 °C 85 °C for code ED |
| F9 | Other | | |

Fitting of the sensor 1 2 3 4 5 6 7 8 9

| 4. code | Description |
|---------|----------------------------------|
| P1E | Spatial for explosive atmosphere |

Nominal length 1 2 3 4 5 6 7 8 9

| 5. code | Dimension L |
|---------|-------------|
| L75 | 75 mm |

Head 1 2 3 4 5 6 7 8 9

| 6. code | Description |
|---------|---|
| H5N | Al alloy, with low cap, ground clamps, cable outlet M20×1.5 for cable Ø 5 to 10 m, IP 65 |
| H5 | Al alloy, with high cap for mounting of transmitter with 62 mm, ground clamps, cable outlet M20×1.5 for cable Ø 5 to 10 mm, IP 65 |
| H6 | Al alloy, ground clamps, thread for cable outlet M20×1.5, IP 68 |
| H7 | Stainless steel, ground clamps, thread for cable outlet M20×1.5, IP 68 |
| H11 | Al alloy, screw cap with chain, without cable gland, ground clamps, IP68 |
| H12 | Stainless steel AISI316, screw cap with chain, without cable gland, ground clamps, IP68 |
| H13 | Al alloy, screw cap with peephole, without cable gland, IP68 |
| H14 | Stainless steel AISI316, screw cap with peephole, without cable gland, IP68 |
| L D | Double cable outlet only for codes H5, H5N |
| L W | Sensor head with peephole for display only for codes H5 Z1E and S2, S3; not for double sensors |
| H9 | Other |

Cold-end of measuring insert 1 2 3 4 5 6 7 8 9

| 7. code | Description |
|---------|---|
| S1 | With ceramic terminal block (diameter 42 mm) on flange of measuring insert |
| S2 | For single sensor, without terminal block, with set for mounting of transmitter on flange of measuring insert (instead of terminal block) |
| S4 | For double sensor, without terminal block, with set for mounting of two transmitters <small>not suitable for H5N, H6 and H7</small> |
| S5 | With ceramic terminal block (diameter 42 mm), embedded pins (according to NAMUR) |
| S9 | Other |

Measuring insert diameter ① ② ③ ④ ⑤ ⑥ ⑦ ⑧ ⑨ ○

| 8. code | Description |
|---------|--------------------------|
| D1 | diameter 3 mm |
| D3 | diameter 6 mm (standard) |

Versions for explosive atmosphere of gasses or dusts ① ② ③ ④ ⑤ ⑥ ⑦ ⑧ ⑨ ○

| 9. code | Description |
|---------|---|
| | Flameproof enclosure “Ex d” only for gasses and protection by enclosure “Ex t” only for dusts, intrinsically safe version “Ex i” for gasses and dusts |
| ED/ET | (Ex) II 2G Ex db IIC T6...T5 Gb, (Ex) II 2D Ex tb IIIC T90°C Db only for heads H6, H7, H11, H12, H13, H14 |
| EI | (Ex) II 2G Ex ia IIC T6...T5°C Gb, (Ex) II 2D Ex ia IIIC T85°C...Tx°C Db only for heads H5, H5N, H6, H7, H11, H12, H13, H14 |
| ET | (Ex) II 2D Ex tb IIIC T90°C Db only for heads H5, H5N |

Optional accessories ① ② ③ ④ ⑤ ⑥ ⑦ ⑧ ⑨ ●

| Code | Indication units |
|------|--|
| Z1E | Intrinsically safe LED display in sensor head (Ex) II 2G Ex ia IIC T6 <small>only for codes H5W and S2, S3; operating temperature -20 to +80 °C</small> |

| Code | Cable outlet *1 |
|------|---|
| KME1 | Cable outlet, nickel-plated brass, Ex d, M20x1.5, IP 68, for fixed assembly cable Ø 4.5 to 8.5 mm |
| KME2 | Cable outlet, nickel-plated brass, Ex d, M20x1.5, IP 68, for fixed assembly cable Ø 7 to 12 mm |
| KME3 | Cable outlet, stainless steel, Ex d, M20x1.5, IP 68, for fixed assembly cable Ø 4 to 8 mm |
| KME5 | Cable outlet, polyamide (light blue), Ex e, M20x1.5, IP 68, for fixed assembly cable Ø 5 to 9 mm, operating temperature -20 to +95 °C <small>not for ED</small> |
| KME6 | Cable outlet, polyamide (light blue), Ex e, M20x1.5, IP 68, for fixed assembly cable Ø 6.5 to 12 mm, operating temperature -20 to +95 °C <small>not for ED</small> |
| KM9 | Other |
| PK1 | Lock anti pull-up cable for Ex d cable outlet KME1 |
| PK2 | Lock anti pull-up cable for Ex d cable outlet KME2 |

*1 – The heads H5, H5N are usually equipped with nickel-plated brass cable outlet for cable with diameter 4 to 12.5 mm.

| Code | Snap lock |
|------|--|
| RU | Snap lock only with codes H5, H5N |

| Code | Calibration in customer defined points, including certificate of calibration |
|--------|---|
| KTE31A | Resistance temperature sensor calibration in three points in range -20 to +100 °C |
| KTE41A | Resistance temperature sensor calibration in four points in range -20 to +100 °C |
| KTE51A | Resistance temperature sensor calibration in five points in range -20 to +100 °C |
| KTE9 | Other |

| Code | Accessories |
|------|---|
| BZS | Stainless steel tag for attachment (70x15 mm) with laser description according to the order |
| PPZ | Laser description of sensor according to the order |

Example of order:
T1070 04 F2 P1E L75 H5 S1 D3 EI KTE31A (-40, 50, 100 °C)

8. Appendix

8.1 Declaration of conformity (standard version)

| | |
|---|---|
|  <p>JSP Industrial Controls</p> | <p>Temperature Sensors – PC9271EN – 2022/08</p> |
|---|---|

EU DECLARATION OF CONFORMITY

We, **JSP, s.r.o.**
 Raisova 547, 506 01 Jičín, Czech Republic
 VAT No. CZ49286684

declare under our sole responsibility that

The Product: Temperature sensor series ModuTEMP® 70

Type/Model: T1070 ... standard version
 T1570 ... standard version

is under the conditions specified in the manual in conformity with the following standards:

| Czech Standards | European Standards |
|---------------------|--------------------|
| ČSN EN 61326-1:2013 | EN 61326-1:2013 |

and following directives:

| Czech Directives | European Directives |
|-------------------------|-----------------------|
| 117/2016 Sb. as amended | 2014/30/EU as amended |
| 481/2012 Sb. as amended | 2011/65/EU as amended |

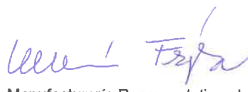
| | |
|--|---|
| Place of Issue: Jičín Date of Issue: 25. 08. 2022 |  Name and Signature of the Manufacturer's Representative: Ing. Vladimír Fryba Function: Chief executive Officer |
|--|---|

JSP, s.r.o. | Raisova 547, Holínské Předměstí, 506 01 Jičín, Czech Republic
 +420 493 760 811 | jsp@jsp.cz | www.jsp.cz

8.2 Declaration of conformity (explosion hazard environment version - code ED/ET)

EU DECLARATION OF CONFORMITY

We, JSP, s.r.o.
Raisova 547, 506 01 Jičín, Czech Republic
VAT No. CZ49286684

declare under our sole responsibility that

The Product: Temperature sensor series ModuTEMP® 70
version with flameproof Exd for use in potentially explosive gases and
version with protection by enclosure Ext for use in potentially explosive dust

Type/Model: T1070 ... H6/H7 ... ED/ET
T1570 ... H6/H7 ... ED/ET

is under the conditions specified in the manual in conformity with the following standards:

| Czech Standards | European Standards |
|-------------------------|---------------------|
| ČSN EN IEC 60079-0:2018 | EN IEC 60079-0:2018 |
| ČSN EN 60079-1:2015 | EN 60079-1:2014 |
| ČSN EN 60079-26:2015 | EN 60079-26:2015 |
| ČSN EN 60079-31:2014 | EN 60079-31:2014 |
| ČSN EN 61326-1:2013 | EN 61326-1:2013 |

and following directives:

| Czech Directives | European Directives |
|-------------------------|-----------------------|
| 116/2016 Sb. as amended | 2014/34/EU as amended |
| 117/2016 Sb. as amended | 2014/30/EU as amended |
| 481/2012 Sb. as amended | 2011/65/EU as amended |

Physical Technical Testing Institute (FTZÚ), Notified Body No. 1026, Registration No. (VAT) CZ00577880, Pikartská 7, 716 07 Ostrava - Radvanice, Czech Republic, tested the product and issued: EC-Type Examination Certificate No. FTZÚ 03 ATEX 0297X, Date of Issue 29.11.2003, and supplement No. 8, Date of Issue 22.12.2023. This Notified Body issued Notification of quality safety No. FTZÚ 02 ATEX Q 011.



Place of Issue: Jičín

Name and Signature of the Manufacturer's Representative: Ing. Vladimír Frýba

Date of Issue: 22. 12. 2023

Function: Chief executive Officer

8.3 Declaration of conformity (explosion hazard environment version - code EI)

EU DECLARATION OF CONFORMITY

We, JSP, s.r.o.
Raisova 547, 506 01 Jičín, Czech Republic
VAT No. CZ49286684

declare under our sole responsibility that

The Product: Temperature sensor series ModuTEMP® 70 with intrinsically safe version Exi for use in potentially explosive gases and dust

Type/Model: T1070 ... H5/H6/H7 ... EI
T1570 ... H5/H6/H7 ... EI

is under the conditions specified in the manual in conformity with the following standards:

| Czech Standards | European Standards |
|------------------------------|--------------------------|
| ČSN EN 60079-0:2013+A11:2014 | EN 60079-0:2012+A11:2013 |
| ČSN EN 60079-11:2012 | EN 60079-11:2012 |
| ČSN EN 61326-1:2013 | EN 61326-1:2013 |

and following directives:

| Czech Directives | European Directives |
|-------------------------|-----------------------|
| 116/2016 Sb. as amended | 2014/34/EU as amended |
| 117/2016 Sb. as amended | 2014/30/EU as amended |
| 481/2012 Sb. as amended | 2011/65/EU as amended |

Physical Technical Testing Institute (FTZÚ), Notified Body No. 1026, Registration No. (VAT) CZ00577880, Pikartská 7, 716 07 Ostrava - Radvanice, Czech Republic, tested the product and issued: EC-Type Examination Certificate No. FTZÚ 13 ATEX 0080X, Date of Issue 25.06.2013, and supplement No. 3, Date of Issue 22.12.2023. This Notified Body issued Notification of quality safety No. FTZÚ 02 ATEX Q 011.

Place of Issue: Jičín

Name and Sign of Representative: Ing. Vladimír Frýba

Date of Issue: 22.12.2023

Function: Chief Executive Officer

8.4 Declaration of conformity (explosion hazard environment version - code ET)

EU DECLARATION OF CONFORMITY

We, JSP, s.r.o.
Raisova 547, 506 01 Jičín, Czech Republic
VAT No. CZ49286684

declare under our sole responsibility that

The Product: Temperature sensor series ModuTEMP® 70
version with protection by enclosure Ext for use in potentially explosive dust

Type/Model: T1070 ... H6/H7 ... ET
T1570 ... H6/H7 ... ET

is under the conditions specified in the manual in conformity with the following standards:

| Czech Standards | European Standards |
|-------------------------|---------------------|
| ČSN EN IEC 60079-0:2018 | EN IEC 60079-0:2018 |
| ČSN EN 60079-31:2014 | EN 60079-31:2014 |
| ČSN EN 61326-1:2013 | EN 61326-1:2013 |

and following directives:

| Czech Directives | European Directives |
|-------------------------|-----------------------|
| 116/2016 Sb. as amended | 2014/34/EU as amended |
| 117/2016 Sb. as amended | 2014/30/EU as amended |
| 481/2012 Sb. as amended | 2011/65/EU as amended |

Physical Technical Testing Institute (FTZÚ), Notified Body No. 1026, Registration No. (VAT) CZ00577880, Pílkartská 7, 716 07 Ostrava - Radvanice, Czech Republic, tested the product and issued: EC-Type Examination Certificate No. FTZÚ 03 ATEX 0297X, Date of Issue 29.11.2003, and supplement No. 8, Date of Issue 22.12.2023. This Notified Body issued Notification of quality safety No. FTZÚ 02 ATEX Q 011.

Place of Issue: Jičín

Name and Signature of the Manufacturer's Representative: Ing. Vladimír Frýba

Date of Issue: 22. 12. 2023

Function: Chief executive Officer



JSP Industrial Controls

JSP, s.r.o.

Raisova 547, 506 01 Jičín

Czech Republic

+420 493 760 811

jsp@jsp.cz

www.jsp.cz

JSP Service Line

+420 605 951 061

www.jsp.cz