

MANUAL

T1025

Resistance Temperature Sensors with Thermowells without/with Transmitter

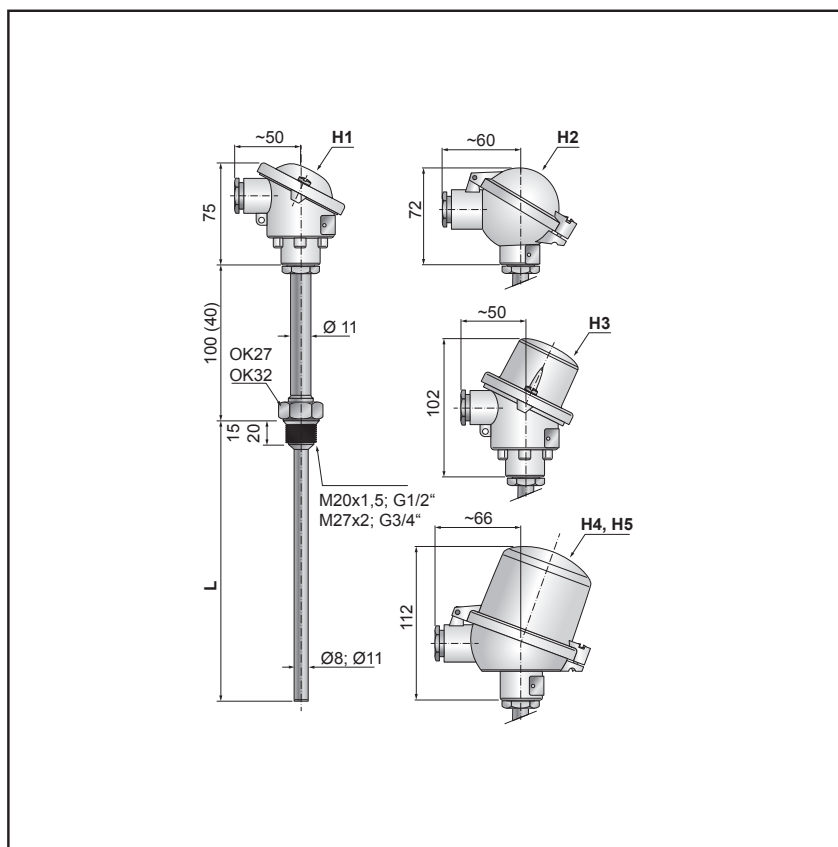

- Measuring resistor 1x / 2x Pt100, Pt500, Pt1000
- Measuring range -40 to +180 °C
- Accuracy class A, B according to EN 60751
- Head form B according to DIN
- Thermowell and extension piece material stainless steel 1.4541
- Selectable thermowell length
- Nominal pressure PN 63
- Housing IP 65
- Optional headmounted transmitter with output 4 to 20 mA, HART, Profibus, Fieldbus, including version with galvanic isolation and intrinsically safe version

Contents

1. General instructions and information	3
1.1 Symbols used	3
1.2 Safety warnings and cautions	3
1.3 Scope of delivery	3
1.4 Description of the delivery and packing	3
1.5 Storage	3
1.6 Installation and commissioning	3
1.7 Spare parts	3
1.8 Repairs	3
1.9 Warranty	3
2. End of service and disposal	3
2.1 End of service	3
2.2 Disposal	3
3. Product description	4
3.1 Application	4
3.2 Description	4
4. Installation, operation and maintenance	4
4.1 Installation and commissioning	4
4.2 Operation and maintenance	5
5. Product specifications	6
5.1 Technical specifications	6
5.2 Operation conditions	6
5.3 Supplementary parameters	6
5.4 Metrological parameters	6
5.5 Supplementary parameters	6
6. Standards and marking	6
6.1 Standards	6
6.2 Marking and type tag information	6
7. Ordering information	7
7.1 Ordering table	7

1. General instructions and information

1.1 Symbols used



Symbol of warning; for safe use it is necessary to proceed according to the instructions



This product does not belong to public waste and it is subjected to separate collection

1.2 Safety warnings and cautions



The equipment may be installed only by a qualified personnel who are familiar with national and international laws, directives, standards and with the instructions manual. The equipment shall be supplied from a safe voltage source that meets all requirements of the standard EN 61010-1 and must be installed in compliance with national requirements and standards providing safety.

The instrument may not be used for other purposes than as specified in this instruction manual. When used with headmounted transmitter, observe also the requirements according to transmitter manual. For elimination of a risk of injury from electric shock or fire, the maximum operational parameters of the instrument may not be exceeded.

1.3 Scope of delivery

With the product is delivered:

- Manual for installation, operation and maintenance
- Certificate of calibration (only with calibrated sensors)
- Copper sealing rings

1.4 Description of the delivery and packing

The product is packaged in a protective cover and provided with an identification label with a mark of the output control.

The product must not be exposed to direct rain, vibrations and shocks during transport.

1.5 Storage

The products shall be stored at temperatures from 5 °C to 35 °C and maximum relative humidity 80% in the rooms with elimination of condensation of water vapours on the products. The stored products shall not be exposed to any shocks, vibrations and effects of harmful vapours and gases.

1.6 Installation and commissioning

During installation, commissioning, operation and maintenance follow the instructions in chapter 4.

1.7 Spare parts

Any of the compact parts of the product can be also ordered as a spare part if there are not required special procedures or technological operations for the exchange. In case of exchange of the measuring sensor or transmitter, it is necessary to perform a calibration in the calibration laboratory of the manufacturer after exchange.

1.8 Repairs

Products are repaired by the manufacturer. The products for repair should be sent in a packing that guarantees damping of shocks and vibrations and protects against damage during transport.

1.9 Warranty

Products are covered by a warranty for a period of 24 months from the delivery date on the delivery note. The manufacturer guarantees technical and operational parameters of the products within scope of the applicable documentation. Warranty period is specified with individual items and begins from the day of takeover of the goods by the purchaser or delivery to the carrier. Any claims concerning to defects of the goods together can be filed in writing with the manufacturer within the warranty period and the claimed product shall be presented. The claiming party shall give identification of the product, number of the delivery note and description of the fault or defect.

The manufacturer is not responsible for any defects caused by improper storage, incorrect connection, damages caused by external effects, in particular by effects of factors with excessive values, unqualified installation, improper operation or common wearing.

2. End of service and disposal

2.1 End of service



Before removing and ending of service of the sensor is at first necessary to switch the control loop to manual operation, or take other appropriate action to prevent potential harm associated with the end of sensor operation. Connected power supply is switched off, the head is opened and connecting wires of the sensor are disconnected (cut off).

2.2 Disposal



When disposing the packing and destroyed or irreparably damaged product proceed according to the local regulations.

3. Product description

T1025

Resistance Temperature Sensors with Thermowells without/with Transmitter

- Measuring resistor 1x / 2x Pt100, Pt500, Pt1000
- Measuring range -40 to +180 °C
- Accuracy class A, B according to EN 60751
- Head form B according to DIN
- Thermowell and extension piece material stainless steel 1.4541
- Selectable thermowell length
- Nominal pressure PN 63
- Housing IP 65
- Optional headmounted transmitter with output 4 to 20 mA, HART, Profibus, Fieldbus, including version with galvanic isolation and intrinsically safe version

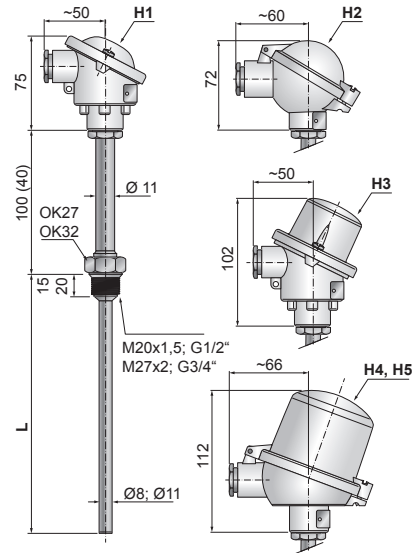

3.1 Application

Resistance temperature sensors T1025 with thermowell are designed for remote measuring of temperature of flowing liquid and gaseous mediums in piping, tanks etc. Sensors can be supplied with connecting terminal or with transmitter mounted in the sensor head.

3.2 Description

A sensor of the thermometer is made of one or two measuring resistors, embedded in the stem of exchangeable measuring insert. Resistors are connected by inner wiring to the terminal block in the sensor head. There is used defined resistance change according to temperature change. At sensors with transmitter is resistance signal further transformed to linearized unified current signal 4 to 20 mA, optionally to HART, Profibus, Fieldbus output. The sensors are mounted by means of a connecting pipe union into a straight or an oblique welded-on piece.

4. Installation, operation and maintenance

4.1 Installation and commissioning

4.1.1 General

Improper depth of sensor immersion to measured medium can cause a measurement deviation because the heat is diverted through a sensor stem and its process connection. To prevent this fault the recommended depth of immersion is 8 to 10 times diameter of thermowell measuring end for liquids and 10 to 15 times diameter of thermowell measuring end for gases.

In case of necessity to mount sensor into pipes of small diameter, it is recommended to mount sensor sideways or into a bend, with thermowell measuring end pointed towards the direction of medium flow. The sensors may be installed in any position with cable outlets facing down if possible. Vertical position with head up is considered as typical position.

Before the installation of sensors with connecting pipe union, the connection thread shall be treated against galling and for easy mounting and dismantling especially to stainless steel fittings or welded on piece, there is danger of galling (of cold weld).

Sensor is fixed by screwing into the straight thread or oblique welded on piece on the wall of the piping, technological equipment, etc.

Connection of wires

Resistance sensor without installed transmitter is connected to the decoding devices using copper connection cable wires with cross section 0.5 to 1.5 mm².

Connection terminal is accessible after removal of the head cover. Drawing of the connection terminals and wiring are shown on the scheme of electrical connection. The sensor outlet shall be carefully sealed after connection of the wires.

Notes:



Pay proper attention to find suitable position of the sensor cable outlet.

The head of all sensors can be turned after loosening the fitting nut (under the head) to desired position of the sensor cable outlet.

4.1.2 Commissioning

Temperature sensor without transmitter in the head is ready for operation after connection of copper connection wires between the sensor terminals and terminals of the associated apparatus and after mounting head cover.

Temperature sensor with transmitter in the head (installed in the head cover) is ready for operation if terminals of the measuring insert and transmitter are connected by the attached

connection wires and after connection of copper connection wires between the transmitter terminals and terminals of the associated apparatus and after mounting head cover.

Temperature sensor with transmitter in the head (installed on the measuring insert flange instead of a ceramic terminal strip) is ready for operation after connection of copper connection wires between the transmitter terminals and terminals of the associated apparatus and after mounting head cover.

4.1.3 Electrical connection

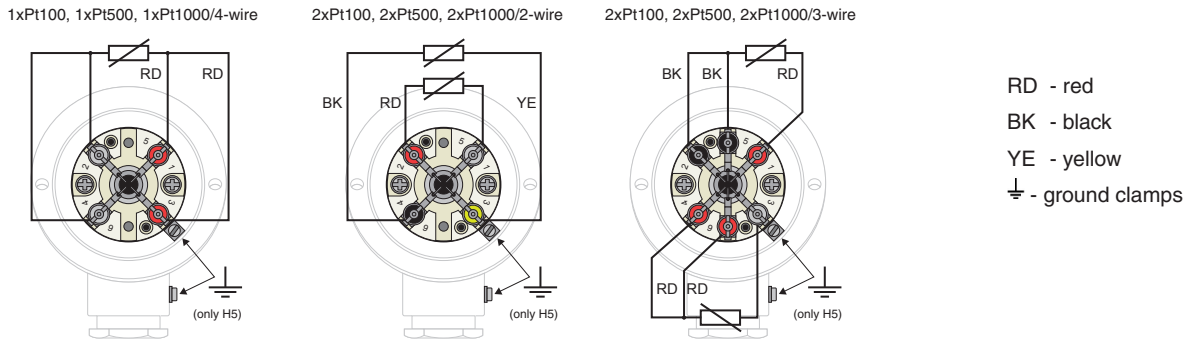

4.1.4 Examples of mounting of the sensors in operation

straight welded on piece

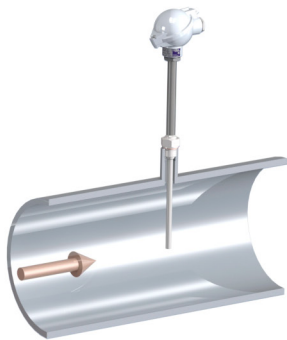

oblique welded on piece



in pipe elbow



4.2 Operation and maintenance

The product does not need any operation or maintenance.

It is recommended to check the mounting of the sensor at preselected intervals.

To ensure metrological parameters of the sensors, periodic checks of calibration parameters must be performed. Period of calibrations is set by the user and it is based on operating conditions and internal metrology regulations. Manufacturer's recommended period is 12 months. If there is during the calibration found difference from the expected metrological parameters, it is necessary to replace the measuring insert.

5. Product specifications

5.1 Technical specifications

Measuring resistor:

1xPt100, 1xPt500, 1xPt1000
accuracy class A, B according to EN 60751,
inside wiring: four-wire,
2xPt100, 2xPt500, 2xPt1000
accuracy class B according to EN 60751,
inside wiring: two-wire,
accuracy class A, B according to EN 60751,
inside wiring: three-wire

Measuring range:

-40 to +180 °C

Measuring current:

Pt100 0.3 to 1 mA
Pt500 0.1 to 0,7 mA
Pt1000 0.1 to 0,3 mA

Output signal:

without transmitter resistance
with transmitter linearized 4 to 20 mA
other after agreement

Dielectric strength: 500 V eff

Electrical insulation resistance:

min. 100 MΩ according to EN 60751,
at temperature (25 ±10)°C, max. 80 % relative humidity

Response time (for 50% temperature change in water):

15 s

Materials:

head - aluminium alloy
stem of measuring insert - stainless steel 1.4401 (AISI 316)
inside wiring - Cu
thermowell - stainless steel 1.4541 (AISI 321)

Housing (according to EN 60529):

IP 65

5.2 Operation conditions

Maximal temperature of head:

100 °C (without transmitter)
85 °C (with transmitter P5310, P5311 and 5335)

5.3 Supplementary parameters

EMC (Electromagnetic Compatibility):

according to EN 61326-1

Weight:

- a) without transmitter with head H1:
Nominal length L: 100 ... 0.65 kg
 160 ... 0.70 kg
 250 ... 0.75 kg
 400 ... 0.80 kg
 630 ... 0.95 kg
- b) with head H2 plus 0.04 kg
 H3 plus 0.05 kg
 H4, H5 plus 0.20 kg
- c) with transmitter P5310 plus 0.04 kg
 P5311 plus 0.05 kg
 5335 plus 0.05 kg

5.4 Metrological parameters

Temperature sensors can be supplied:

- as sensors with calibration,
- as sensors without calibration.

Tolerance limits of accuracy classes are listed in EN 60751. The initial tolerance is related to the initial calibration of the sensor. Drift of the sensor meets the requirements of EN 60751, Sec. 6.5.3. To ensure accuracy of measurement, it is necessary to calibrate sensors periodically according to the operating parameters. Sensors can be supplied with calibration at several temperature points, according to customer requirements. Sensor to the transmitter can also be supplied with calibration including transmitter with current output signal of 4 to 20 mA.

5.5 Supplementary parameters

5.5.1 General

EMC (electromagnetic compatibility):

according to EN 61326-1

Lifetime

Lifetime of the product cannot be exactly determined, it depends on the operational conditions.

It is necessary to take into account that lifetime (reliability) of the temperature sensors may be significantly reduced e.g. by chemical corrosiveness or abrasion or erosion effects of the measured medium, effects of vibrations or shocks and surges (caused by flowing of the medium or transferred to the sensor from the external environment, such as from big rotary machines, etc.), cyclic temperature changes, fast temperature changes, use of the sensors at the upper limit of the temperature range, etc.

5.5.2 Version with transmitter

Sensors with single sensor and with head H3, H4, H5 may be completed with transmitters into heads (outer diameter of transmitter 44 mm; span of fixing screws M4 - 33 mm). Transmitter with diameter up to 64 mm can be also mounted into the head cover H4 and H5.



Using the transmitter in sensor head is possible if temperature of sensor head in place of application does not exceed max. allowed ambient temperature of transmitter. This temperature is typically 80 °C or 85 °C according to used transmitter. The temperature of the head may be increased by transferring heat from the process.

Applicable transmitters

For range of transmitter see category optional accessories in transmitters for head mounting and the catalogue transmitters.



For application with headmounted transmitter, observe also the requirements according to transmitter manual.

6. Standards and marking

6.1 Standards

Electromagnetic compatibility:
EN 61326-1

6.2 Marking and type tag information

Marking on temperature sensors head

Aluminium or stainless steel tag (example):

T1025-3 01 1 116	type number (version number) - incomplete marking	11030267 IP 65	serial number housing
1xPT100/B/4	number of sensors, sensor material, value of basic resistance, accuracy class, version of inside wiring	Czech Republic  www.jsp.cz	country of origin logo JSP, s.r.o. website address
-40 ..180 °C	temperature range		

7. Ordering information

7.1 Ordering table

Type	Description
◦ T1025-3	Resistance temperature sensor with thermowell
Code	Temperature sensor Measuring range Inside wiring material
◦ 01	1xPt100, four-wire inside wiring -40 to +180 °C Cu
◦ 03	1xPt1000, four-wire inside wiring -40 to +180 °C Cu
◦ 04	2xPt100, two-wire inside wiring -40 to +180 °C Cu
◦ 06	2xPt1000, two-wire inside wiring -40 to +180 °C Cu
◦ 54	2xPt100, three-wire inside wiring -40 to +180 °C Cu
◦ 56	2xPt1000, three-wire inside wiring -40 to +180 °C Cu
99	Other
Code	Accuracy class according to EN 60751
◦ 1	B
◦ 2	A (only for sensor with three-wire or four-wire inside wiring)
Code	Nominal length L [mm]
◦ 110	100
◦ 116	160
◦ 125	250
◦ 140	400 (standard only for thermowell Ø 11 mm)
◦ 163	630 (standard only for thermowell Ø 11 mm)
999	Other
Code	Thermowell - outer diameter [mm] Material
◦ J10	Ø 8 mm, cylindrical 1.4541
J20	Ø 11 mm, cylindrical 1.4541
J99	Other
Code	Extension piece - outer diameter [mm] Length [mm] Material
◦ N1	Ø 11 mm (not for thermowell Ø 11mm) 40 1.4541
N2	Ø 11 mm 100 1.4541
N9	Other
Code	Head
◦ H1	Al alloy, with terminal board, for cable diameter 4 to 12.5 mm, housing IP 65
◦ H2	Al alloy, with terminal board, for cable diameter 4 to 12.5 mm, housing IP 65
◦ H3	Al alloy, with cap for mounting of transmitter Ø 44 mm, with terminal board, for cable diameter 4 to 12.5 mm, housing IP 65
◦ H4	Al alloy, with cap for mounting of transmitter Ø 62 mm, with terminal board, for cable diameter 4 to 12.5 mm, housing IP 65
H5	Al alloy, with cap for mounting of transmitter Ø 62 mm, with terminal board, ground clamps, for cable diameter 5 to 10 mm, housing IP 65
H9	Other
Code	Process connection
◦ P1	M20x1.5
◦ P2	G1/2"
P3	M27x2 (not for thermowell Ø 8 mm (code J10))
P4	G3/4" (not for thermowell Ø 8 mm (code J10))
P9	Other
Code	OPTIONAL ACCESSORIES
	Calibration in customer defined points, including certificate of calibration
◦ KTE31A	Resistance temperature sensor calibration in three points in range -40 to +180 °C
◦ KTE41A	Resistance temperature sensor calibration in four points in range -40 to +180 °C
◦ KTE51A	Resistance temperature sensor calibration in five points in range -40 to +180 °C
KTE9	Other
Code	Transmitters for headmounting
• P5310 H10	Transmitter with LHP protocol (see data sheet No. 0824)
◦ P5310EN2 H10	Transmitter with LHP protocol, (Ex) II 3G Ex nA IIC T4 Gc (see data sheet No. 0824)
• P5311 H10	Transmitter with LHP protocol with galvanic isolation (see data sheet No. 0824)
◦ P5311EN2 H10	Transmitter with LHP protocol with galvanic isolation, (Ex) II 3G Ex nA IIC T4 Gc (see data sheet No. 0824)
◦ P5311E11 H10	Transmitter with LHP protocol with galvanic isolation, (Ex) II 1G Ex ia IIC T4-T6 Ga, (Ex) II 1D Ex ia IIC T106°C Da (see data sheet No. 0824)
• P5315 H10	Precision transmitter with LHP protocol with galvanic isolation (see data sheet No. 2098)
P5315EN2 H10	Precision transmitter with LHP protocol with galvanic isolation, (Ex) II 3G Ex nA [ic] IIC T4 Gc (see data sheet No. 2098)
• P5320 H10	Precision transmitter with HART protocol with galvanic isolation (see data sheet No. 0825)
• P5320EN2 H10	Precision transmitter with HART protocol with galvanic isolation, (Ex) II 3G Ex nA [ic] IIC T4 Gc (see data sheet No. 0825)
P5320E11 H10	Precision transmitter with HART protocol with galvanic isolation, (Ex) II 1G Ex ia IIC T4-T6 Ga, (Ex) II 1D Ex ia IIC Txx°C Da (see data sheet No. 0825)
Example of order: T1025-3 01 1 110 J10 N1 H3 P1 KTE31A (-40, 50, 150 °C)	
• ... Ex stock version	◦ ... Marked version can be dispatched up to 5 working days (with calibration up to two weeks)



JSP Industrial Controls

JSP, s.r.o. | Raisova 547, 506 01 Jičín, Czech Republic
+420 493 760 811 | export@jsp.cz | www.jsp.cz

Your Supplier: