

MANUAL

P5320

Precision Programmable Transmitters with HART Communication



- Precision transmitter for resistance and thermocouple sensors and potentiometers.
- Current output signal 4 to 20 mA with HART communication.
- Accuracy 0.05 % in reference conditions and 0.17 % throughout the temperature range.
- Linearization with zero error, normalized polynomials are directly used.
- Galvanic isolation 1000 VAC
- Double-channels version to DIN rail with removable spring or screw terminals.
- Span adjustability from 1 to 100 %.
- Easy configuration by handheld communicator (475 or HARTConf) or by a program HARTWinConf and standard HART modem.
- Intrinsically safe version (Ex) II 1G and (Ex) II 2D.
- Extended warranty 5 years.

Content

1. General instructions and information	3	5. Product specifications	10
1.1 Symbols used	3	5.1 Technical specifications:	10
1.2 Safety cautions and warnings	3	5.2 Supplementary parameters	11
1.3 Scope of delivery	3	6. Tests, certificates and standards	12
1.4 Description of the delivery and packing	3	6.1 Tests, certificates	12
1.5 Storage	3	6.2 Standards	12
1.6 Installation and commissioning	3	6.3 Marking and type tag information	12
1.7 Spare parts	3	6.4 Specific conditions for use of a transmitter in an intrinsically safe version EI1 and EI3:	12
1.8 Repairs	3	7. Objednání	13
1.9 Warranty	3	7.1 Objednací tabulka	13
2. End of service and disposal	4	8. Přílohy	15
2.1 End of service	4	8.1 Prohlášení o shodě (provedení pro prostředí s nebezpečím výbuchu – kódy EI1, EI3)	15
2.2 Disposal	4		
3. Product description	5		
3.1 Application	5		
3.2 Description	5		
3.3 Dimensional drawings	6		
3.4 Block diagram	6		
4. Installation, operation and maintenance	7		
4.1 Installation and commissioning	7		
4.2 Description of setting and configuration using the com- municator HARTWinCom	9		
4.3 Operation and maintenance	9		

1. General instructions and information

1.1 Symbols used



Warning symbol; for safe use proceed according to the instructions



The symbol CE approves conformity of the product with legal requirements of the EU



Symbol "Output"



Symbol "Power supply"



This product does not belong to public waste and it is subjected to separate collection



The product meets requirements for explosion hazard environment according to the further specification

HART

Remote communication protocol for reading and changing of the configuration, registered trademark HART Communication Foundation

1.2 Safety cautions and warnings



The transmitter shall be powered from a safe voltage source that meets all requirements of the standard EN 61010-1 and shall be installed in compliance with national requirements and standards providing safety. The equipment may only be installed by a qualified personnel who are familiar with national and international laws, directives, standards and with the instructions manual. The instrument must not be used for other purposes than as specified in this instructions manual.

For elimination of a risk of injury from electric shock or fire the maximum operational parameters of the instrument must not be exceeded, particularly range of operating temperature because of exposure to heat from connected or surrounding technological equipment must not be exceeded!

The transmitter should be installed in suitable environment without any direct sunlight, occurrence of dust, high temperatures, mechanical vibrations and shocks and protected against rain and excessive moisture.

1.3 Scope of delivery

With the product is delivered:

- Manual for installation, operation and maintenance
- Certificate of calibration (only with calibrated transmitters)
- Copy of EU certificate on type examination ATEX (only transmitters for explosion hazard environment)

1.4 Description of the delivery and packing

The product is packaged in a protective cover and provided with an identification label with a mark of the output control. The product must not be exposed to direct rain, vibrations and shocks during transport.

1.5 Storage

The products shall be stored at temperatures from -40 to +80 °C without condensation of water vapours.

1.6 Installation and commissioning

During installation, commissioning, operation and maintenance follow the instructions in chapter 4.

1.7 Spare parts

Any of the compact parts of the product can be also ordered as a spare part if there are not required special procedures or technological operations for the exchange.

1.8 Repairs

Products are repaired by the manufacturer. The products for repair should be sent with description of the fault or defect in a packing that guarantees damping of shocks and vibrations and protects against damage during transport.

1.9 Warranty

Products are covered by a warranty for a period of 5 years from the delivery date on the delivery note. The manufacturer guarantees technical and operational parameters of the products within scope of the applicable documentation. Warranty period is specified with individual items and begins from the day of takeover of the goods by the purchaser or delivery to the carrier. Any claims concerning to defects of the goods can be filed in writing within the warranty period and shall be presented to the manufacturer together with the claimed product. The claiming party shall give identification of the product, number of the delivery note and description of the fault or defect.

2. End of service and disposal

2.1 End of service

 Dismounting and disposal of the device is possible after disconnecting of power supply voltage.

2.2 Disposal

 The product does not contain any environmentally harmful parts. When disposing the packing and destroyed or irreparably damaged product proceed according to the local regulations.

3. Product description

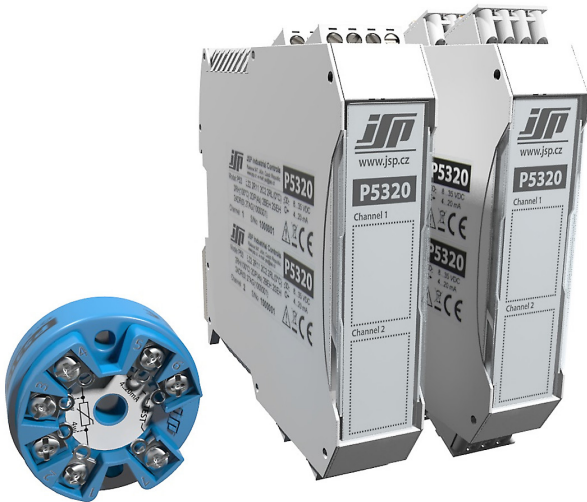

P5320 Precision Programmable Transmitters with HART Communication

- Precision transmitter for resistance and thermocouple sensors and potentiometers.
- Current output signal 4 to 20 mA with HART communication.
- Accuracy 0.05 % in reference conditions and 0.17 % throughout the temperature range.
- Linearization with zero error, normalized polynomials are directly used.
- Galvanic isolation 1000 VAC
- Double-channels version to DIN rail with removable spring or screw terminals.
- Span adjustability from 1 to 100 %.
- Easy configuration by handheld communicator (475 or HARTConf) or by a program HARTWinConf and standard HART modem.
- Intrinsically safe version (Ex) II 1G and (Ex) II 2D.
- Extended warranty 5 years.

3.1 Application

Transmitters P5320 H10 and P5320 Lxx are used for conversion of a resistance or voltage temperature signal from a resistance or thermocouple temperature sensor to a linearized current loop output signal 4 to 20 mA. The transmitter type H1x is designed for installation into an industrial sensor head of type A or B according to DIN 43729. Transmitters P5320 include galvanic isolation of inputs and outputs and are also suitable for applications with many measuring points and for thermocouples.

3.2 Description

The input signal is processed by the A/D converter to a digital signal. Then it is processed by a microcomputer, which, according to the configuration, calculates after noise filtering all the measured values. From these values, the primary value (usually the temperature) and also the output current is calculated according to the set range.

One resistance sensor (two-, three- or four-wire) can be connected to the input. In case of a two-wire connection, entering of a constant value of the loop resistance compensation during configuration of the transmitter can compensate the resistance of input leads. In other cases, the leads resistance is compensated automatically. A thermocouple can be also connected to the input. According to respective configuration, the cold junction compensation (CJC) is realized either using an internal sensor inside the transmitter, an external sensor in the transmitter terminal block, a defined constant temperature or an external sensor outside the transmitter. The inner sensor guarantees maximum accuracy and stability of cold junction temperature measurement of P5320 H10. For accurate measurement of thermocouples by DIN rail transmitters P5320 Lx0 the setting of external compensation and use of compensation terminal CTB3 / CTB4 is needed.

In addition to standard resistance sensors, it is also possible to process a signal of potentiometer position, which is measured either as a linear resistance sensor (when Ω is chosen as a unit) or as a relative position of the slider (if % is chosen) calculated as the ratio of the resistances. The start position is 0% and the end position is 100% regardless of the value of the total resistance. The transmitter provides analog output signal of the current loop 4 to 20 mA with HART digital communication. The current output can be also used for tests of the current loop and the associated equipment. HART communication is used to configure the transmitter and to read remotely the measured variables. In order to set up the transmitter, you need a PC with HARTWinConf SW and HART modem HART-Mod (MH-02) or an equivalent communication interface. You can also use handheld communicator 475 or HARTConf. The transmitter communicates using HART protocol, revision 7.

3.3 Dimensional drawings

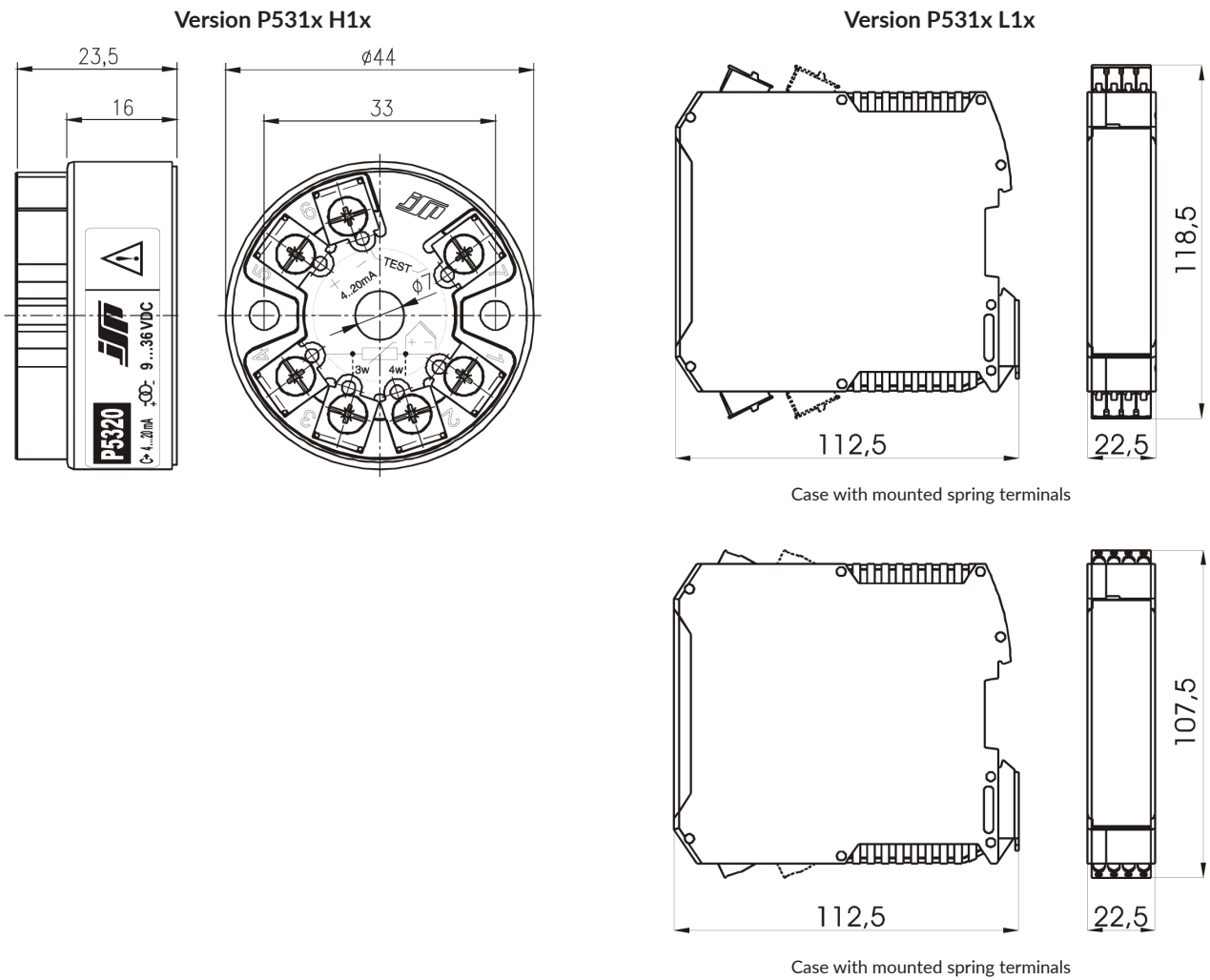

3.4 Block diagram

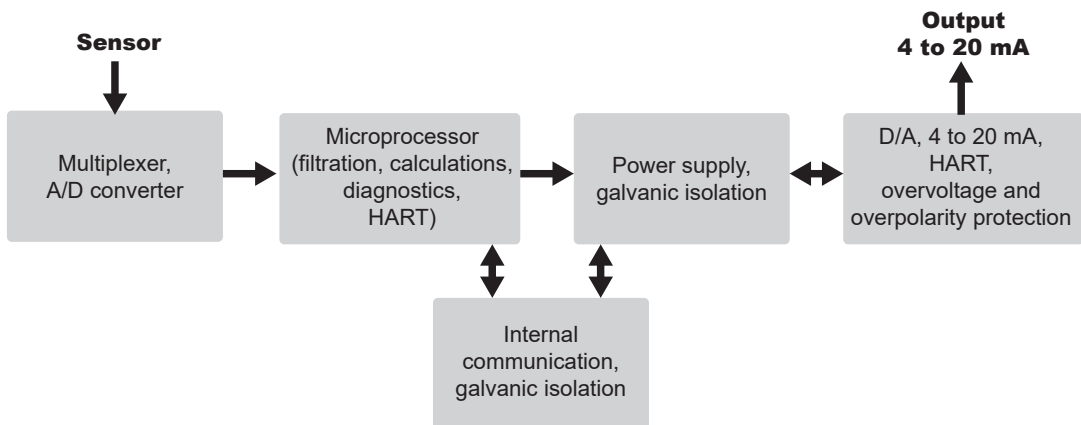

4. Installation, operation and maintenance

4.1 Installation and commissioning

4.1.1 General

After mounting and correct connection, switch on the power supply.

During the installation of transmitters in environment with higher level of interference, protection of transmitters against interference and induced overvoltage must be ensured. According to the standard engineering practice, it is recommended to separate signal and power wires into separate gutters and use shielded signal cables with twisted wires. In case of outdoor wires, it is necessary to solve the overvoltage protection of the transmitter as a part of overall solution of protecting system from the effects of atmospheric electricity.

4.1.2 Specific conditions for use of a transmitter in an intrinsically safe version (code EI1 and EI3)

Ex II 1G Ex ia IIC T6...T4 Ga
 II 2D Ex ia IIIC T61°C...T106°C Db



The device must not be installed in the areas where external conditions could result in electrostatic charging. In the cases of a transmitter in H10 version that is located in zone 0 and gas group IIC and a transmitter in Lx0 version located in any explosive gaseous atmosphere and in any zone, an electrostatic charge capable of initiating may occur on the plastic surface of the enclosure under certain extreme circumstances. The device may only be wiped with a damp cloth. A suitable placement is, for example, an installation in a metal sensor head or in a metal enclosure that does not contain aluminium, magnesium, titanium and zirconium. During installation it is also necessary to respect other safety standards. The transmitter may be connected on its input and output sides only to suitable certified associated apparatus or simple apparatus in the sense of the standard EN 60079-11 with respecting of the limiting conditions. The transmitter may be installed in an environment with explosion hazard Zone 0, Zone 1 or Zone 2 only if all the related conditions are fulfilled. The device provides the necessary level of protection during normal operation and with one or two faults.

A transmitter located in an explosive dust atmosphere must be located in a enclosure meeting the requirements of ČSN EN 60079-11:2012, chapter 6.1.3, paragraph a). Such case may be a metal temperature sensor head or a suitable metal installation box that does not contain magnesium, titanium with the certification for the use in potentially explosive environments. During installation it is also necessary to respect other safety standards. The transmitter may be connected on its input and output sides only to suitable certified associated apparatus or simple apparatus in the sense of the standard EN 60079-11 with respecting of the limiting conditions. The transmitter may be installed in an environment with explosion hazard Zone 20, Zone 21 or Zone 22 only if all the related conditions are fulfilled. The equipment provides the necessary level of protection during normal operation and with one or two faults.

Galvanic isolation of input and output electrical circuit is not faulty free isolation in terms of Intrinsic safety and it should be taken into account during the safety analysis of the system.

4.1.3 Electrical connection

Version P5320 H10

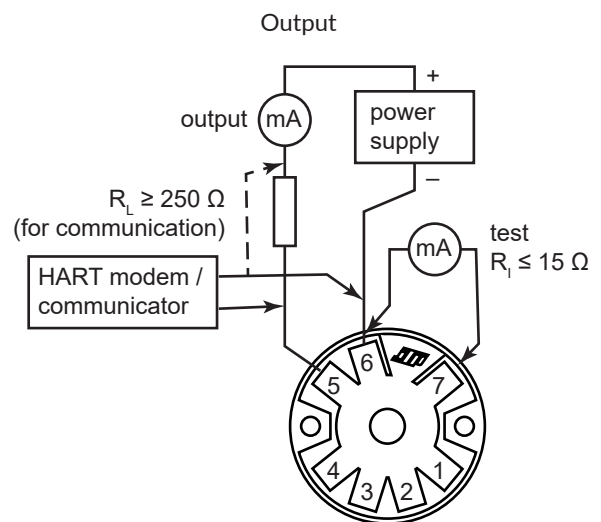
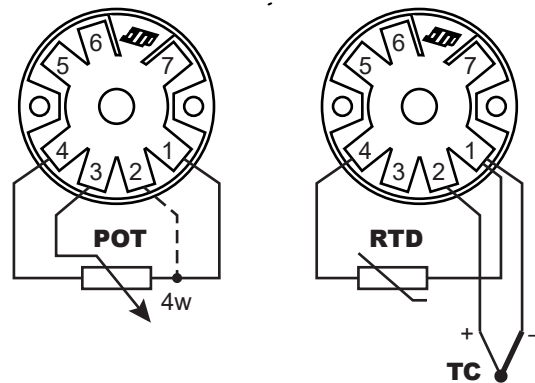
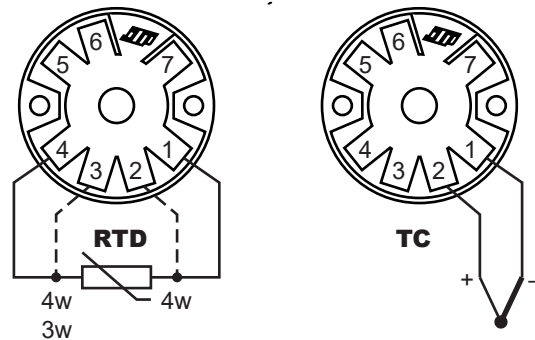

Version P5320 Lx0

Designation	Description	Terminals No.
A	Output 1. channel	15, 15, 17, 19
B	Output 2. channel	25, 26, 27, 28
C	Input 1. channel	11, 12, 13, 14
D	Input 2. channel	21, 22, 23, 24

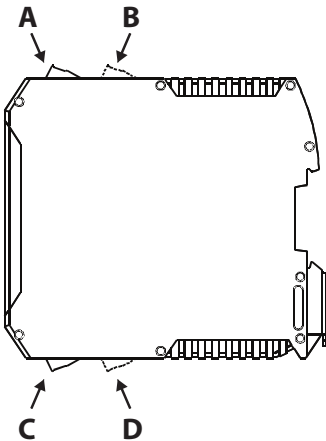

Left: input RTD or R
Right: input potentiometer

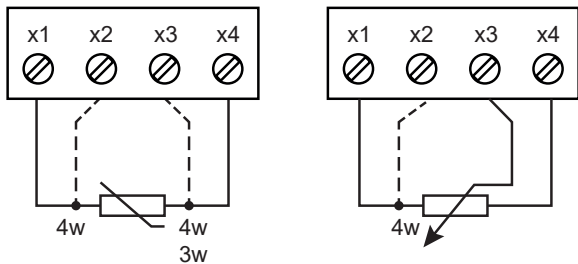

Left: input TC, CJC compensation terminal *1
Right: input TC, const. CJC or voltage *2

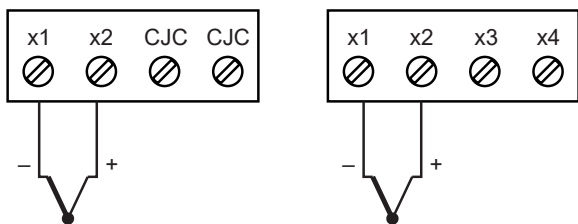

input TC, external CJC

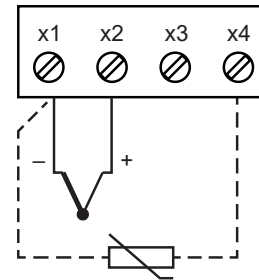

Output *3

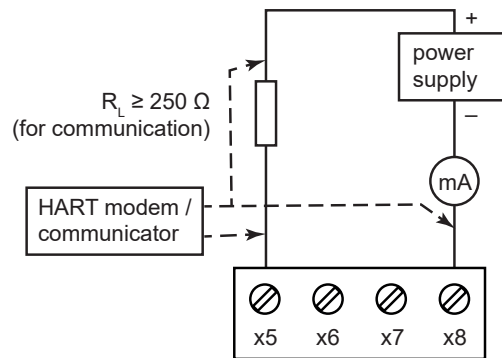

*1 ... Connection of the thermocouple to compensation terminal CTB3 / CTB4. Compensation terminal includes a built-in sensor Pt1000A for accurate temperature measurement of cold junction of connected thermocouple. When using the compensation terminals, it is necessary to set the compensation configuration of cold junction to an external sensor Pt1000, it means the use of the built-in sensor of the compensation terminal!

Compensation terminals are standard included in the delivery of version P5320 L10 and L20 and they can be also ordered separately for each channel (code CTB3 and CTB4, see ordering table).

*2 ... This connection can be used only for measurement of thermocouples with constant temperature of cold junction or for measurement of thermocouple B.

*3 ... Symbol "x" in description of terminals represents the number of the channel. In case of single channel version, the symbol „x" is always substituted by symbol "1", and in case of dual channel version this represents the number of channel, i.e. "1" or "2".

4.2 Description of setting and configuration using the communicator HARTWinCom

The communicator HARTWinCom consists of program HARTWinConf, modem HARTMod (MH-02) and connection cables. Before use is necessary to connect the modem to a PC using the connection cable, install and run the program HARTWinConf. Program finds the modem on the respective communication port by itself. In case, that the program issues a message that the modem is not connected, enter the respective port on the HART driver panel.

The program includes three main configuration panels. The "Device Info" panel describes the connected transmitter, the "Basic Setup" panel is used to set the range or units, the "Detailed Setup" panel is used to set the sensor type and how it is connected. The program allows for the setting all available parameters of the transmitter. Configuration can be saved as a file or print it as a "Transmitter Configuration Protocol"

The "Setup" menu can also be accessed from the menu, where you can change the program language, for example, and the "Service" menu, where the fixed output mode can be started. This mode changes the transmitter into a very accurate simulator of output current with the range 3.5 to 22 mA. In this mode the output current is determined by the entered value only and is not influenced by changes of the input quantity. The fixed output mode can be closed by the program button or by disconnecting of the transmitter power supply.



Transmitters in version E11 (Ex version) can be set up using the communicator HARTWinCom only if the transmitter, communicator and connected wires are installed out of explosion hazard environment!

4.3 Operation and maintenance

Provided that the instrument is installed correctly, the operator can read setting and measured values using a configurator. Setting of the instrument may be changed only if a sudden change of the output current cannot cause any failure of the technological equipment or regulation (switch over the possible regulator to manual control)!

The instrument does not need any maintenance.

5. Product specifications

5.1 Technical specifications:

Supply voltage:

Basic version 9 to 35 V_{SS}
 Version EI1 and EI3 9 to 30 V_{SS}
 (internally protected against polarity inversion and short-term overvoltage)

Range of ambient temperatures:

-40 to 85 °C

Reference ambient temperature:

23 ± 5 °C

Housing:

Version H10 IP40, terminals IP00
 after installation to the head
 the housing is given by the design
 of the head

Version Lx0 IP20

Humidity:

Version H10 0 to 100 % RH with condensation
 after installation to the head

Version Lx0 10 to 80 % RH with condensation

Connection of wires:

Version H10 Screw terminals
 for cross section 0,5 to 1,5 mm²,
 torque 0,5 Nm

Version Lx0 Spring or screw terminals
 for cross section 0,5 to 1,5 mm²,
 torque 0,5 Nm

Warm-up time:

5 s

Type of DIN rail:

TS 35 according DIN 46277

Dimensions (H×W×D):

H10 Ø 44 × 24 mm
 Lx0 120 × 23 × 107 mm

Material of cases:

H10 polycarbonate
 Lx0 polyamide

Weight:

H10 35 g
 Lx0 110 g

Working position:

arbitrary

5.1.1 Input

Input ranges:

Input type	Basic range	Standard
RTD input	0 to 400 Ω	---
RTD input	0 to 6000 Ω	---
potentiometer	0 to 100 % (Rd = 40 to 6000 Ω)	---
voltage input	-100 to 100 mV	---
Pt100	-200 to 850 °C	EN 60751
Pt500	-200 to 850 °C	EN 60751
Pt1000	-200 to 850 °C	EN 60751
Pt50 a=0,00391	-200 to 850 °C	GOST 6651
Pt100 a=0,00391	-200 to 850 °C	GOST 6651
Ni100	-60 to 260 °C	DIN 43760
Ni1000	-60 to 260 °C	DIN 43760
Cu50 a=0,00428	-180 to 200 °C	GOST 6651
Cu100 a=0,00428	-180 to 200 °C	GOST 6651
thermocouple "J"	-210 to 1200 °C	IEC 584-1
thermocouple "K"	-270 to 1370 °C	IEC 584-1
thermocouple "N"	-270 to 1300 °C	IEC 584-1
thermocouple "R"	-50 to 1770 °C	IEC 584-1
thermocouple "S"	-50 to 1770 °C	IEC 584-1
thermocouple "T"	-270 to 400 °C	IEC 584-1
thermocouple "B"	0 to 1820 °C	IEC 584-1
thermocouple "E"	-270 to 1000 °C	IEC 584-1
thermocouple "L"	-200 to 900 °C	DIN 43710
thermocouple "C"	0 to 2320 °C	N.I.S.T. Monograph 175
thermocouple "GOST L"	-200 to 800 °C	GOST R 8.585

Digital accuracy:

Input 0 to 400 Ω ≤ ±0,05 % MV or ≤ ±0,04 Ω
 or corresponding temperature,
 ≤ ±0,1 % or ≤ ±0,08 Ω,
 for potentiometer with set units %

Input 0 to 6000 Ω ≤ ±0,05 % MV or ≤ ±0,4 Ω
 or corresponding temperature
 for values up to 4000 Ω,
 ≤ ±0,1 % MV in range
 4000 až 6000 Ω,
 ≤ ±0,1 % or ≤ ±0,8 Ω
 for potentiometer with set units %

Input -100 to 100 mV ≤ ±0,05 % MV or ≤ ±0,01 mV
 or corresponding temperature
 (the highest value is valid; accuracy of measured value of
 digital output HART)

Input signal:

Resistance signal of temperature sensor or
 potentiometer, voltage signal of thermocouple

Sensor connection:

Resistance sensor	two-, three-, four-wire
Voltage sensor (TC)	two-wire
Potentiometer	three-wire or four-wire
Compensation using an external sensor	two-wire

Maximum wire resistance for resistance ranges:
 < 20 Ω (each connecting wire)

Current through resistance sensor:
 < 0,15 mA

Input overloading:
 max. 24 V_{DC} or max. 18 mA between any inputs (max. 60 s)

Measurement error of Internal compensation temperature (compensation error): < ±1 °C

Effect of wire resistance for resistance ranges:

Two-wire connection	can be compensated by constant value
Three-wire connection	no effect with identical values of wire resistance
Four-wire connection	no effect with specified wire resistance range

Input resistance:
 > 10 MΩ

5.1.2 Output

Output signal:
 Two-wire 4 to 20 mA or 20 to 4 mA

Total measurement error on the analog output of P5320:

Range 0 to 400 Ω	≤ ±0.05 % SR or ≤ ±0.04 Ω or corresponding temperature ≤ ±0.1 % or ≤ ±0.08 Ω for potentiometer with set units %
Range 0 to 6000 Ω	≤ ±0.05 % SR or ≤ ±0.4 Ω or corresponding temperature for values up to 4000 Ω, ≤ ±0.1 % SR in range 4000 to 6000 Ω, ≤ ±0.1 % or ≤ ±0.8 Ω for potentiometer with set units %
Range -100 to 100 mV	≤ ±0.05 % SR or ≤ ±0.01 mV or corresponding temperature
Range Pt100, Pt1000, Ni100, Ni1000	≤ ±0.05 % SR or ≤ ±0.1 °C
Range Pt500	≤ ±0.05 % SR or ≤ ±0.2 °C
Range TC J, K, N, T, E, L	typ. ≤ ±0,05 % SR or 0,2 °C
Range TC R, S, B, C	typ. ≤ ±0,05 % SR or 0,5 °C

(the highest value is valid; in the case of the ranges with suppressed start of range, the error is multiplied by the suppression coefficient = end of range/range span)

Characteristics:
 Linear with temperature or linear with input quantity, other upon request

Adjustability of the range:
 ±1 % to ±100 % of the input range

Adjustability:
 within limits of the input range

Time constant (95 %):
 Adjustable 0.5 s (for damping 0 s) to 60 s (approx. 3 measurements per second)

Load resistance:
 $R_L [\Omega] \leq (U_N [V] - 9) / 0,022$

Dielectric strength of galvanic isolation:
 1000 V_{AC} (test)

Dielectric strength of between channels P5320 L20:
 2500 V_{AC} (test)

Isolation resistance of galvanic isolation:
 > 100 MΩ

5.2 Supplementary parameters

Output current limitation:
 Signal 3.8 to 20.5 mA according to NAMUR NE43
 Limitation of error current to approx. 22 mA

Indication of sensor or transmitter error:
 Configurable, by current > 21 mA or < 3.6 mA according to NAMUR NE43

Supply voltage effect:
 ≤ ±0,005 % / V

Influence of ambient temperature changes:

Range 0 to 400 Ω	(≤ ±0,025 % SR or ≤ ±0,04 Ω or corresponding temper.) / 10 °C
Range 0 to 6000 Ω	(≤ ±0,025 % SR or ≤ ±0,4 Ω or corresponding temper.) / 10 °C
Range -100 to 100 mV	(≤ ±0,025 % SR or ≤ ±0,01 mV or corresponding temper.) / 10 °C

(the highest value is valid; in the case of the ranges with suppressed start of range, the error is multiplied by the suppression coefficient = end of range/range span)

Long-term stability:
 ≤ ±0,1 % of the preset range per 2 years

Electromagnetic compatibility:
 Radiation and immunity acc. to EN 61326-2-3

MV ... measured value,
 SR ... span of preset range,
 Rd ... total resistance of resistor path of the potentiometer

6. Tests, certificates and standards

6.1 Tests, certificates

Electromagnetic compatibility, Emission and immunity:
acc. to EN 61326-2-3

Intrinsically safe version (option EI1 and EI3):
certificate FTZÚ 16 ATEX 0063X

6.2 Standards

Transmitter is designed and manufactured according to these standards:
EN 61010-1
Version EI1 and EI3: EN 60079-0, EN 60079-11

6.3 Marking and type tag information

Standard version:

P5320	type number
Model:	version
S/No:	serial number
Czech Republic	country of origin
	logo of JSP, s.r.o.
www.jsp.cz	contact for manufacturer

Tag of version EI1

includes further:

 II 1G Ex ia IIC T6...T4 Ga
II 2D Ex ia IIIC T61°C...T106°C Db

year of manufacture
number of ATEX certificate

Tag of version EI3

includes further:

 II 1G Ex ia IIC T6...T4 Ga
II 2D Ex ia IIIC T61°C...T106°C Db

year of manufacture
number of ATEX certificate
ATTENTION - Danger of electrostatic charge

6.4 Specific conditions for use of a transmitter in an intrinsically safe version EI1 and EI3:

Relation between the temperature class and ambient temperature:

T4 (T106 °C)	$-40\text{ °C} < T_{AMB} < +85\text{ °C}$
T5 (T76 °C)	$-40\text{ °C} < T_{AMB} < +55\text{ °C}$
T6 (T61 °C)	$-40\text{ °C} < T_{AMB} < +40\text{ °C}$

Output

Supply (Terminal H10 ... 5 and 6; Lxx ... x5, x8):

$U_i = 30\text{ VDC}$
$I_i = 100\text{ mA}$
$P_i = 0,9\text{ W}$
$L_i = 350\text{ }\mu\text{H}$
$C_i = 0\text{ nF}$

Output test

(Terminal 6 and 7, it is designed only for temporary connection of a multimeter):

$U_o = 30\text{ V}_{SS}$
$I_o = 100\text{ mA}$
$P_o = 0,9\text{ W}$
$L_o = 100\text{ }\mu\text{H}$
$C_o = 0\text{ nF}$

Input for sensor:

$U_o = 6,6\text{ V}_{SS}$
$I_o = 21\text{ mA}$
$P_o = 0,034\text{ W}$
$L_o = 70\text{ mH}$
$C_o = 1\text{ }\mu\text{F}$

For other conditions see chapter:

"4.1.2 Specific conditions for use of a transmitter in an intrinsically safe version (code EI1 and EI3)" on page 7.

7. Ordering information

7.1 Ordering table

Type		1	2	3	4
1. code	Description				
P5320	Precision programmable transmitter with HART communication				
Version		1	2	3	4
2. code	Description				
H10	Into head form B according to DIN				
L10	Single-channel on the DIN rail TS 35 with removable screw terminals (plus compensation terminal CTB3)				
L20	Double-channel on the DIN rail TS 35 with removable screw terminals (plus compensation terminals CTB3 and CTB4)				
Setting requirements		1	2	3	4
3. code	Description				
NR	No requirements for the range and input setting (preset: Pt100, three-wire connection of sensor, 0 to 100 °C)				
QR	Range and other parameters setting according to configuration sheet DB0998				
*1 - For code QR configuration sheet DB0998 is required to the order.					
Calibration		1	2	3	4
Code	Description				
KPP5	Certificate of calibration, transmitter calibration in five equally spaced points in the set range				
Optional version		1	2	3	4
Code	Description				
EI1	Intrinsically safe version (Ex) II 1G Ex ia IIC T6...T4 Ga, (Ex) II 2D Ex ia IIIC T61°C...T106°C Db only for version P5320 H10				
EI3	Intrinsically safe version (Ex) II 1G Ex ia IIC T6...T4 Ga, (Ex) II 2D Ex ia IIIC T61°C...T106°C Db only for version P5320 Lxx				
Volitelné příslušenství		1	2	3	4
Code	Terminals				
TB1	Two exchangeable spring terminals				only for version L10
TB2	Four exchangeable spring terminals				only for version L20
CTB3	Compensation terminal for measuring thermocouple sensors, channel 1				only for version Lxx
CTB4	Compensation terminal for measuring thermocouple sensors, channel 2				only for version Lxx
Code	Settings				
HARTWinCom USB1	Set of configuration program HARTWinConf (CZ+EN) for PC, modem HARTMod and interface USB-RS232C				
HARTConf	HART-USB modem and field communicator for LHP and HART transmitters, function of transmitter supply supplied from USB or inbuilt accumulator, charged from USB				
HM-USB-ISO	HART modem with USB interface and galvanic isolation				
Pt1000A	Compensation resistor Pt1000 (-30 to +150 °C) for external compensation of thermocouple				
Code	Mounting accessories				
S51	Box for wall mounting of one transmitter to explosive atmosphere (IP 68) (Ex) II 2G Ex db IIC T6, T5 Gb + (Ex) II 2D Ex tb IIIC T50/60/80°C Db 2 cable glands KMEx have to be ordered				
S52	Box for wall mounting of one transmitter with LED display to explosive atmosphere (IP 68) (Ex) II 2G Ex db IIC T6, T5 Gb + (Ex) II 2D Ex tb IIIC T50/60/80°C Db 2 cable glands KMEx have to be ordered				

Code	Mounting accessories
S54	Wall mounted box (100x100x58 mm), housing IP 65 only for version H10, not for E11, E13 Possibility of installing one transmitter
S55	Wall mounted box (170x145x85 mm), housing IP 55 only for version L10, not for E11, E13 Possibility of installing up to three transmitters
S56	Wall mounted box (100x100x58 mm), housing IP 65 only for version H10, not for E11, E13 Possibility of installing two transmitters
VH1	Cap for head form B for transmitter mounting only for version H1x
APT1	Adapter for flat head
Code	Cable glands
KME1	Cable outlet, nickel silver, Ex d, IP 68, for fixed assembly cable with diameter Ø 4,5 to 8,5 mm
KME2	Cable outlet, nickel silver, Ex d, IP 68, for fixed assembly cable with diameter Ø 7 to 12 mm
KME3	Cable outlet, stainless steel, Ex d, IP 68, for fixed assembly cable with diameter Ø 4 to 8 mm
KME5	Cable outlet, polyamide, Ex ie, IP 68, for fixed assembly cable with diameter Ø 5 to 9 mm, operating temperature -20 to 95 °C
KME6	Cable outlet, polyamide, Ex ie, IP 68, for fixed assembly cable with diameter Ø 6,5 to 12 mm, operating temperature -20 to 95 °C

Example of order:
P5320 H10 QR

8. Appendix

8.1 Declaration of conformity (model protected by intrinsic safety – code EI1 and EI3)

 JSP Industrial Controls	Transmitters – PB9266EN – 2022/03
--	-----------------------------------

EU DECLARATION OF CONFORMITY

We, **JSP, s.r.o.**
 Raisova 547, 506 01 Jičín, Czech Republic
 VAT No. CZ49286684

declare under our sole responsibility that

The Product: Universal Programmable Transmitter

Type/Model: P5320 H10 EI1 and P5320 Lx0 EI3

is under the conditions specified in the manual in conformity with the following standards:

Czech Standards	European Standards
ČSN EN 61326-2-3:2013	EN 61326-2-3:2012
ČSN EN IEC 60079-0:2018	EN IEC 60079-0:2018
ČSN EN 60079-11:2012	EN 60079-11:2012

and following directives:

Czech Directives	European Directives
117/2016 Sb. as amended	2014/30/EU as amended
116/2016 Sb. as amended	2014/34/EU as amended
481/2012 Sb. as amended	2011/65/EU as amended

No changes of the product were required to enable compliance with the above updated standards.

Physical Technical Testing Institute (FTZÚ), Notified Body No. 1026, Registration No. (VAT) CZ00577880, Pikartská 7, 716 07 Ostrava - Radvanice, Czech Republic, tested the product and issued: EU-Type Examination Certificate No. FTZÚ 16 ATEX 0063X, Date of Issue 21.02.2017 with Amendment No.1, Date of Issue 11.02.2022 and Quality Assurance Notification No. FTZÚ 02 ATEX Q011.

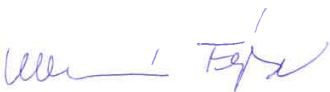

Place of Issue: Jičín	Name and Signature of the Manufacturer's Representative: Ing. Vladimír Frýba
Date of Issue: 01. 03. 2022	Function: Chief Operations Officer

JSP, s.r.o. | Raisova 547, Holínské Předměstí, 506 01 Jičín, Czech Republic
 +420 493 760 811 | jsp@jsp.cz | www.jsp.cz



JSP Industrial Controls

JSP, s.r.o.

Raisova 547, 506 01 Jičín

Czech Republic

+420 493 760 811

jsp@jsp.cz

www.jsp.cz

JSP Service Line

+420 605 951 061

www.jsp.cz