

MANUAL

FlexiTEMP® 60

Flexible Sheath Resistance and Thermocouple Temperature Sensors



- Measuring resistor 1× / 2× Pt100, thermocouple 1× / 2× / 3× "J", "K", "N", "T".
- Measuring range -200 to +700 °C (Pt100), -200 to +800 °C ("J"), -200 to +1300 °C ("K", "N"), -200 to +350 °C ("T").
- Accuracy class A, B according EN 60751, 1, 2, 3 according EN 60584-1.
- Sheath material stainless steel 1.4541, 1.4404, Inconel 600, Nicrobell/Pyrosil.
- Sheath diameter from 1 to 6 mm.
- Optional nominal length L: 0.1 to 50 m.
- Fast response to temperature changes.
- Flexible stem.
- Optional version of cold junction, with flying leads, connected compensating cable, flat connector, LEMO connector, flange and MA head.
- Intrinsically safe version (Ex) II 1/2G Ex ia IIC T6...Tx°C Ga/Gb, (Ex) II 2D Ex ia IIIC T85°C...Tx°C Db.

Content

1. General instructions and information	3	5. Product specifications	10
1.1 Symbols used	3	5.1 Technical specifications	10
1.2 Safety warnings and cautions	3	5.2 Operation conditions	11
1.4 Description of the delivery and packing	3	5.3 Metrological parameters	11
1.5 Storage	3	5.4 Supplementary parameters	11
1.6 Installation and commissioning	3	6. Tests, certificates, standards and marking	12
1.7 Spare parts	3	6.1 Tests and certificates	12
1.8 Repairs	3	6.2 Standards and directives	12
1.9 Warranty	3	6.3 Marking and type tag information	12
2. End of service and disposal	4	7. Ordering information	13
2.1 End of service	4	7.1 Ordering table	13
2.2 Disposal	4	8. Appendix	18
3. Product description	5	8.1 Declaration of conformity (standard version)	18
3.1 Application	5	8.2 Declaration of conformity (explosion hazard environ- ment version - codes EI)	19
3.2 Description	5		
3.3 Dimensional drawings	6		
4. Installation, operation and maintenance	7		
4.1 Installation and commissioning	7		
4.2 Operation and maintenance	9		

1. General instructions and information

1.1 Symbols used



Symbol of warning; for safe use it is necessary to proceed according to the instructions.



Symbol CE certifies compliance of the product with the respective government directives.



This product does not belong to public waste and it is subjected to separate collection.



The product meets requirements for explosion hazard environment.

RTD

Resistance sensor

TC

Thermocouple

1.2 Safety warnings and cautions



The equipment may be installed only by a qualified personnel who are familiar with national and international laws, directives, standards and with this instruction manual.

The equipment shall be supplied from a safe voltage source that meets all requirements of the standard EN 61010-1 and must be installed in compliance with national requirements and standards providing safety.

The instrument may not be used for other purposes than as specified in this instruction manual. When the sensor is used with transmitter, observe also the requirements according to transmitter manual. For elimination of a risk of injury from electric shock or fire, the maximum operational parameters of the instrument may not be exceeded.

1.3 Scope of delivery

With the product is delivered:

- Manual for installation, operation and maintenance
- Certificate of calibration (only with calibrated sensors)
- Copy of EC certificate on type examination ATEX (only sensors for explosion hazard environment)

1.4 Description of the delivery and packing

The product is packaged in a protective cover and provided with an identification label with a mark of the output control. The product must not be exposed to direct rain, vibrations and shocks during transport.

1.5 Storage

The products shall be stored at temperatures from +5 °C to +35 °C and maximum relative humidity 80 % in the rooms with elimination of condensation of water vapours on the products. The stored products shall not be exposed to any shocks, vibrations and effects of harmful vapours and gases.

Sensors with fiberglass insulation of wires must be stored in a dry environment.

1.6 Installation and commissioning

During installation, commissioning, operation and maintenance follow the instructions in chapter 4.

1.7 Spare parts

Any of the compact parts of the product can be also ordered as a spare part if there is not required special procedures or technological operations for the exchange.

1.8 Repairs

Products are repaired by the manufacturer. The products for repair should be sent in a packing that guarantees damping of shocks and vibrations and protects against damage during transport.

1.9 Warranty

Products are covered by a warranty for a period of 24 months from the delivery date on the delivery note. The manufacturer guarantees technical and operational parameters of the products within scope of the applicable documentation. Warranty period is specified with individual items and begins from the day of takeover of the goods by the purchaser or delivery to the carrier. Any claims concerning to defects of the goods together can be filed in writing with the manufacturer within the warranty period and the claimed product shall be presented. The claiming party shall give identification of the product, number of the delivery note and description of the fault or defect.

The manufacturer is not responsible for any defects caused by improper storage, incorrect connection, damages caused by external effects, in particular by effects of factors with excessive values, unqualified installation, improper operation or common wearing.

2. End of service and disposal

2.1 End of service



Before removing and ending of service of the sensor is at first necessary to switch possible control loop to manual operation, or take other appropriate action to prevent potential harm associated with the end of sensor operation. For sensors with head, the head is opened, connecting wires of the sensor are disconnected (cut off) and sensor is dismantled. For sensors with electric power supply is possible to dismantle the sensor after the power supply is switched off.

2.2 Disposal



The products do not contain any environmentally hazardous parts. When disposing the packing and destroyed or irreparably damaged product proceed according to the local regulations.

3. Product description

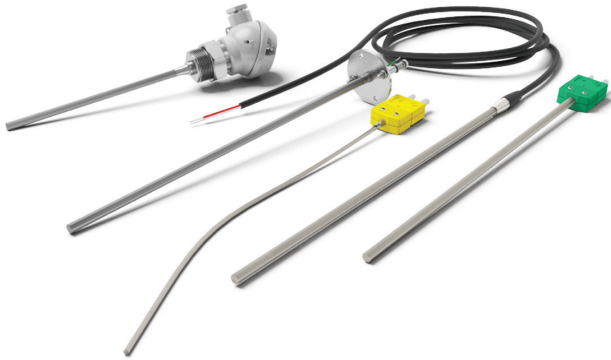

FlexiTEMP® 60 – Flexible Sheath Resistance and Thermocouple Temperature Sensors

- Measuring resistor 1× / 2× Pt100, thermocouple 1× / 2× / 3× “J”, “K”, “N”, “T”.
- Measuring range -200 to +700 °C (Pt100), -200 to +800 °C (“J”), -200 to +1300 °C (“K”, “N”), -200 to +350 °C (“T”).
- Accuracy class A, B according EN 60751, 1, 2, 3 according EN 60584-1.
- Sheath material stainless steel 1.4541, 1.4404, Inconel 600, Nicrobell/Pyrosil.
- Sheath diameter from 1 to 6 mm.
- Optional nominal length L: 0.1 to 50 m.
- Fast response to temperature changes.
- Flexible stem.
- Optional version of cold junction, with flying leads, connected compensating cable, flat connector, LEMO connector, flange and MA head.
- Intrinsically safe version
(Ex) II 1/2G Ex ia IIC T6...Tx°C Ga/Gb,
(Ex) II 2D Ex ia IIIC T85°C...Tx°C Db.

3.1 Application

Resistance and thermocouple temperature sensors FlexiTEMP® 60 without the protective fitting are intended for applications, where their advantages such as fast response to temperature changes, flexible stem, small dimensions and sheath resistance to corrosion become apparent.

High accuracy and stability of output signal are strong sides of resistance sensors. Thermoelectric sensors are very resistant to high pressure, usable in vacuum and have higher stability of output signal in comparison to wire thermocouples.

Standard thermocouple sensors with isolated measuring end are due to its electromagnetic shielding suitable for work together with measuring centers and control systems.

Resistance and thermocouple sensors can be used with or without fastening elements as for example fixing shift pipe unions etc. Version of sensor with flange is suitable as a part of sensor without protective fitting, into thermowell and with thermowell (e.g. ModuTEMP® 70).

3.2 Description

Flexible sheath resistance and thermocouple temperature sensors FlexiTEMP® 60 without protective tubes and thermowells are supplied in length from 100 mm up to several tens of meters with an outer diameter of the sheath 3 / 4.5 / 6 mm (Pt100) and 0.5 / 0.8 / 1 / 1.5 / 2 / 3 / 4.5 / 6 mm (TC “J”, “K”, “N”). These thermocouples are as standard supplied with the sheath made of stainless steel 1.4404 for resistance sensors, 1.4541 for thermocouple “J” or Inconel 600 (2.4816), Nicrobell/Pyrosil for thermocouple “K” and “N”. Resistance sensors are supplied with single or double sensor Pt100.

Measuring ends of thermocouple sensors are manufactured in insulated single or dual sensor. After agreement the grounded or opened version or triple version can be supplied.

Cold ends of sheath resistance sensors and thermocouples are supplied with flying leads, with connected connection wires (for or compensation wires for TC) with optional isolation material, with flat standard connector or mini connector (only for TC), small head MA (with or without connecting thread) or with 42 mm diameter flange with option to mount ceramic terminal block or transmitter (exchangeable measuring insert). Sheath resistance and thermocouple sensors with mineral isolation may be freely bent (resistance sensors cannot be bent in length 40 mm from measuring end) while observing the minimal radius of the bend (5x outer diameter of the sheath).

3.3 Dimensional drawings

Note: Marking of zones for potentially explosive atmosphere (applies for EI version)

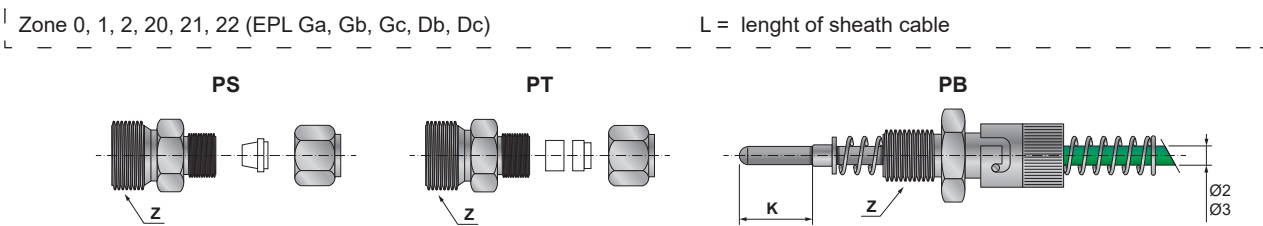
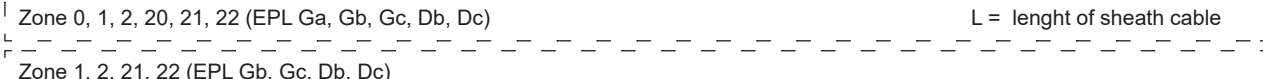
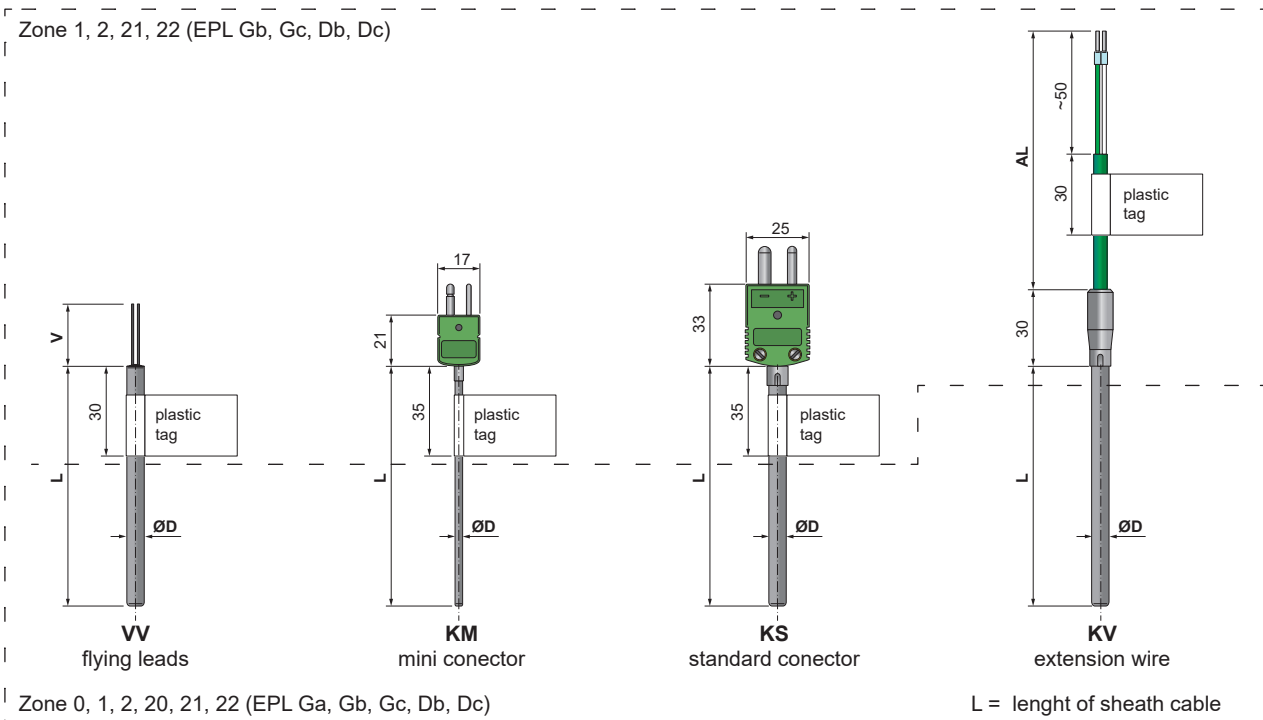

4. Installation, operation and maintenance

4.1 Installation and commissioning

4.1.1 General

Low depth of sensor immersion to measured medium can cause a measurement deviation because the heat is diverted through a sensor stem, protective tube or thermowell. To prevent this fault the recommended depth of immersion is 8 to 10 times diameter of thermowell measuring end for liquids and 10 to 15 times diameter of thermowell measuring end for gases.

Sensors may be installed in any position. In version with head MA (code H1 resp. H1G..) with cable outlets facing down or to the side if possible.

Vertical position with head up or cable outlet up is considered as a standard position.

Sensor with head (code H1) is in case of necessity fixed on wall by holder (D3). Sensor with head (code H1G..) is fixed by screwing into the thread of welded on piece or into the bore on the pipe wall, technological equipment, etc.

Cable sensors (code VV, KV, KS, KM) are fixed to the technology by fixing shift pipe union as standard. Using without fixing shift pipe union is not excluded in some applications.

Resistance sensors are connected to the decoding devices using copper connection cable wires with cross section 0.5 to 1.5 mm². When the sensor is used in the environment with higher level of interference, it is recommended to connect the shield wire according to usual engineering practice. The stem is not electrically connected to the shield.

Thermocouple sensors are connected to the decoding devices using extension or compensation cable wires with cross section 0.22 to 1.5 mm².

Connection terminal of sensors with head is accessible after removal of the head cover. Drawing of the connection terminals and wiring of cable sensors, sensors with connector, and sensors with head are shown on the scheme of electrical connection. The sensor outlet shall be carefully sealed after connection of the wires.

4.1.2 Commissioning

Resistance temperature sensor without head (with flying leads, with connected connection wires) is ready for operation after connection of flying leads or copper connection wires to the terminals of the associated apparatus and after switching on the power supply.

Resistance temperature sensor with head is ready for operation after connection of copper connection wires between the sensor terminals and terminals of the associated apparatus (transmitter, digital display etc.), mounting head cover and after switching on the power supply.

Thermocouple temperature sensor without head (with flying leads, with connected compensation wires, with connector) is ready for operation after connection of flying leads of thermo-

couple or compensation (extension) wires to the terminals of the associated apparatus (transmitter, thermostat of comparator connections, devices with inner compensation etc.) or after connection of sensor with connector to the other part of the connector with connected compensation wires connected to the associated apparatus

Thermocouple temperature sensor with head is ready for operation after connection of compensation (extension) wires between the sensor terminals and terminals of the associated apparatus (transmitter, thermostat of comparator connections, devices with inner compensation etc.) and after mounting head cover.

Before commissioning, check whether the measuring circuit break has not occurred and if the insulation resistance has not been lowered.

4.1.3 Special conditions for safe use of sensors in Intrinsically safe version (code EI)

1. Temperature sensors in intrinsically safe version (code EI) can be connected to intrinsically safe circuits of electrical equipment Group II. Degree of protection and placement of specific versions in specific areas of explosive atmospheres are described in section 3.3. Temperature sensor without transmitter does not have any own ignition source. All potential sources of ignition are brought from environment (electric energy causing warming and thermal energy from a technological connection) and their size and safety (danger) must be assessed by the user during installation. Input parameters of the sensor without the transmitter are $U_i = 30 \text{ V}$, $I_i = 30 \text{ mA}$, $P_i = 0,1 \text{ W}$. Sensor with length 1 m has a maximum internal parameters $C_i = 1 \text{ nF}$ and $L_i = 0,020 \text{ mH}$. In case of longer sensor, these values should be multiplied by the length of the sensor. Input parameters of the sensor with transmitter/display installed in the sensor head are given by parameters of used transmitter/display.

2. When connecting the sensor into the intrinsically safe circuit, these circuits must be considered to be electrically connected to earth potential through the grounded sheath of the sensor. The user must eliminate other connection of intrinsically safe circuit to earth potential using associated apparatus (transmitter, Ex barriers) galvanic isolated from the other circuits. Associated apparatus shall meet the requirements of EN 60079-11. During installation is also necessary to respect the requirements of EN 60079-14, EN 60079-25 and other relevant standards.

3. Sensors do not have ground terminals. Their connection with the ground potential is necessary to ensure by other means in accordance with the relevant standards (for example by access to the technology).

4. Measurement part of the sensor has surface temperature equal to the temperature of the process fluid and therefore it is crucial for determining the temperature class (for T6 to T1) or the maximum surface temperature T_x .

5. The surface temperature of sensor head depends on the

sensor type, method of installation, process temperature, ambient temperature and power loss of used transmitter. Temperature class of temperature sensor head with mounted transmitter/display with max power $P_{max} = 1\text{ W}$ is T4 according to EN 60079-0 with ambient temperature up to 80 °C. Used transmitter/display and associated apparatus must have a type certificate in accordance with the relevant standards and regulations. Final intrinsically safe circuit has to be assessed according to EN 60079-25. If further warming of head due to heat transfer of technology can occur, it is necessary to determine the temperature class based on information from manual or based on measuring surface temperature according to relevant standards.

6. Temperature of other sensor surfaces that are in contact with explosive atmosphere must be determined individually after on-site installation and must not exceed the ignition temperature of the explosive gas atmosphere and/or exceed 2/3 of T_{cl} - ignition temperature of scattered dust.

7. If the measuring end of sensor in version EI is installed in zone 0 or 1, and if electric power P_0 of intrinsically safe transmitter passed into the sensor is higher than 0.05 W, the increase of temperature of the measuring end in the case of failure of the transmitter can exceed 10 °C. In this case, it is necessary to determine real increase of temperature of measuring end under these conditions and to assess the ignition risk of explosion. When installed in Zone 2, transmitter failure is not considered and is sufficient if the power passed into the sensor does not exceed 0.05 W. Information about maximum power passed into the sensor can be found in the operating manual of the transmitter or associated apparatus.

8. During installation it should be taken into account, that the equipment does not meet requirements EN 60079-11, strength test 500 V≈.

9. Maximal temperature of process (measured) medium for explosion hazard environment of gases and temperature classes are listed in the following table.

Temperature class	Maximal surface temperature	Max. temperature of measured medium
T1	450 °C	440 °C
T2	300 °C	290 °C
T3	200 °C	195 °C
T4	135 °C	130 °C
T5	100 °C	95 °C
T6	85 °C	80 °C

For process temperature (measured medium) $440\text{ °C} < T_m \leq 1200\text{ °C}$, the maximal surface temperature of sensor T_x is determined from maximal temperature of the process (measured medium) T_m and safety addition 10 °C.

$$T_x = T_m + 10\text{ °C}$$

10. Maximal surface temperature T_x for dust explosive atmosphere is equal to measured medium temperature T_m .

$$T_x = T_m$$

4.1.4 Electrical connection

RTD cable versions

RD – red | WH – white | BK – black | YE – yellow

1× Pt100/2-wire

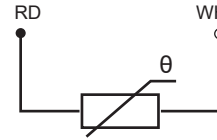

1× Pt100/4-wire

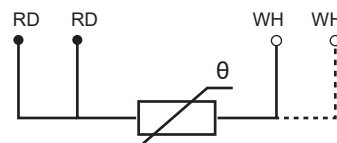

2× Pt100/2-wire

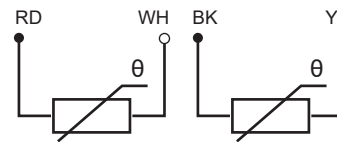

2× Pt100/3-wire /4-wire

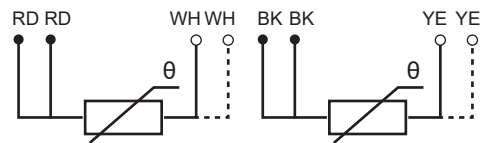

RTD with head MA

RD – red

1× Pt100/2-wire

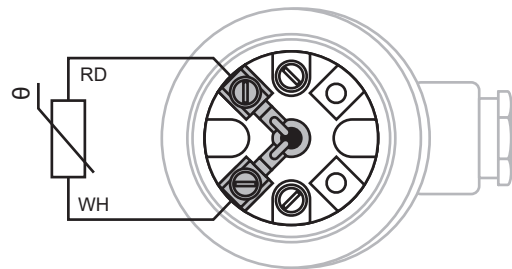

1× Pt100/4-wire

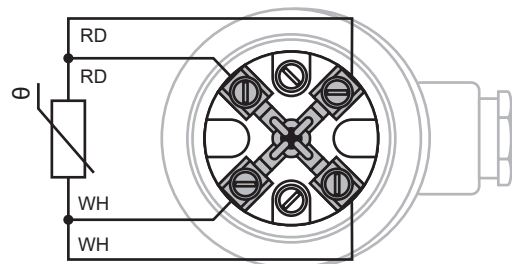

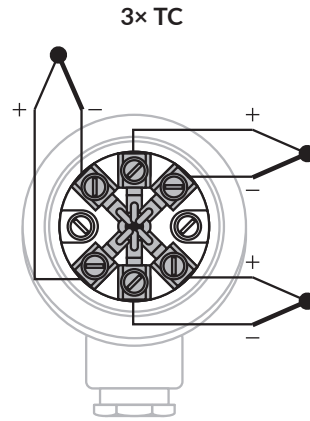
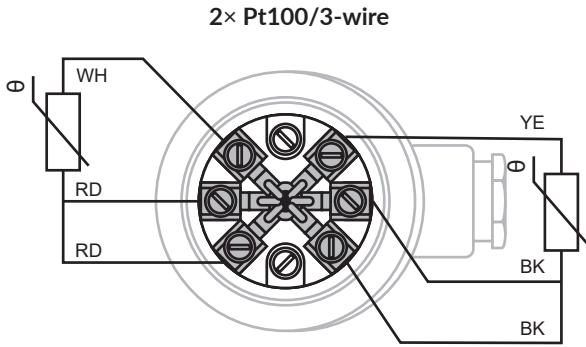

TC cable versions

(+) BK - black | GN - green | PK - pink | BR - brown
 (-) WH - wheel

Thermocouple Type	Color (+)	Color (-)
"J"	BK	WH
"K"	GN	WH
"N"	PK	WH
"T"	BR	WH

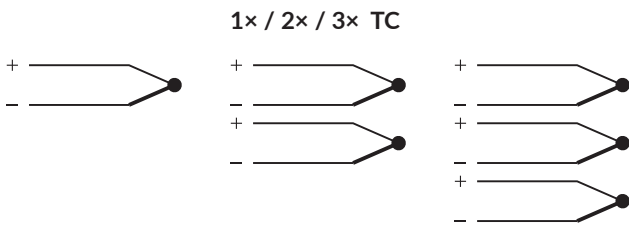

TC with head MA

BK - black | GN - green | PK - pink

1x / 2x TC

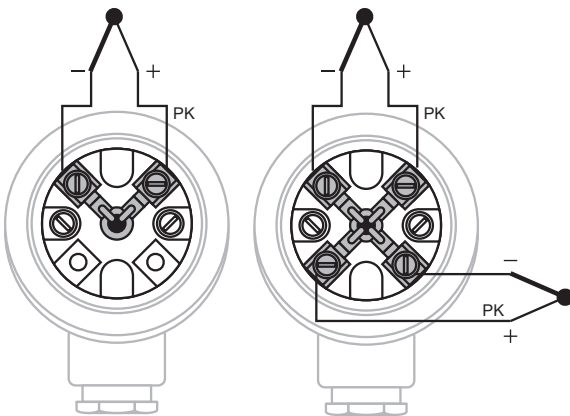

4.1.5 Examples of mounting of the sensors in operation

Sensors without thermowell, respectively protective tube, fixing shift pipe union

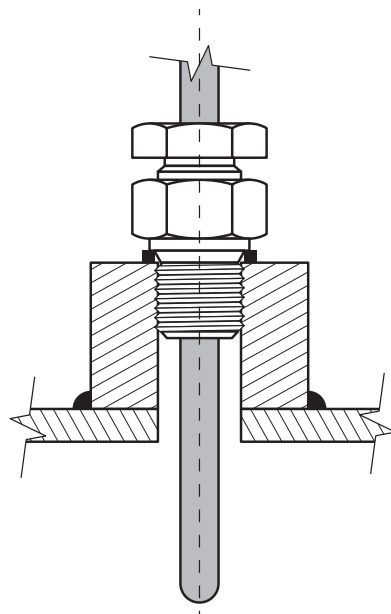

4.2 Operation and maintenance

The products do not need any operation and maintenance.

It is recommended to check the mounting of the sensor at preselected intervals.

To ensure metrological parameters of the sensors, periodic checks of calibration parameters must be performed. Period of calibrations is set by the user and it is based on operating conditions and internal metrology regulations. Manufacturer's recommended period is 12 months. If there is during the calibration found calibration difference from the expected metrological parameters, it is necessary to replace the sensor.

5. Product specifications

5.1 Technical specifications

Resistance sensors type T1060

Measuring resistor (RTD):

1xPt100, accuracy class A, B according to EN 60751
 inside wiring: two-wire, four-wire, outer diameter of stem 3 and 6 mm
 2xPt100, accuracy class A, B according to EN 60751,
 inside wiring: two-wire, three-wire, four-wire, outer diameter of stem 3 and 6 mm

Measuring range:

-200 to +700 °C (accuracy class B)
 -100 to +450 °C (accuracy class A)

Measuring current:

recommended 0.1 to 1.0 mA
 maximal 3 mA

Output signal:

resistance

Electrical insulation resistance:

min. 100 MΩ according to EN 60751,
 at temperature (20 ±15)°C, max. 80 % relative humidity

Thermocouple sensors type T1560

Thermocouple (TC):

1x / 2x / 3x "J", "K", "N", "T"
 accuracy class 1, 2, 3
 according to EN 60584-1, EN 60584-3

Measuring range:

-200 to +800 °C ("J")
 -200 to +1300 °C ("K", "N")
 -200 to +350 °C ("T")

Output signal:

voltage

Electrical insulation resistance *1:

min. 1000 MΩ according to EN 61515,
 at temperature (20 ±15)°C, max. 80 % relative humidity

Version of measuring junction::

1 - Steel sheath | 2 - Thermocouple wires
 3 - Ceramic insulation | 4 - Hot junction

Insulated single and double TC

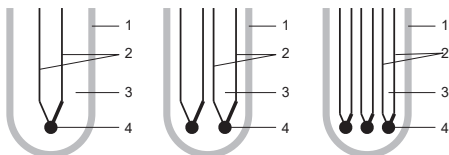

Grounded and opened version

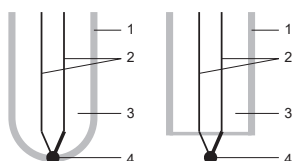

General

Response time:

see next table

Time response of resistance temperature sensors [s] (reference values)

RTD Sheath diameter [mm]	in water v = 0.4 m/s		in air v = 2 m/s	
	T0.5	T0.9	T0.5	T0.9
6 mm	5.5	15	90	295
4,5 mm	4.2	12	78	247
3 mm	1.4	4.5	32	98

Time response of thermocouple temperature sensors [s] (reference values for version with insulated measuring end)

TC Sheath diameter [mm]	in water v = 0.4 m/s		in air v = 2 m/s	
	T0.5	T0.9	T0.5	T0.9
6 mm	3	9	55	170
4,5 mm	2.5	6.5	34	113
3 mm	1	2.8	22	64
2 mm	0.8	2.6	13	34
1,5 mm	0.4	0.9	10	25
1 mm	0.2	0.6	7,5	17

Dielectric strength *1:

250 V eff (outer stem diameter 1.5 to 2 mm)
 250 V eff (outer stem diameter 3 mm / four-wire)
 500 V eff (outer stem diameter 4.5 to 6 mm)
 500 V eff (outer stem diameter 3 mm / two-wire)
 at temperature (20 ±15)°C

Materials:

sheath of resistance sensor: stainless steel 1.4404
 inside wiring of resistance sensor: Cu, Ni
 sheath of thermocouple: stainless steel 1.4541 ("J")
 alloy Inconel 600 (2.4816), Microbell/Pyrosil ("K", "N")

Connection wires (RTD):

2× 0.5 mm², 4× 0.22 mm² stranded wire
 silicone outer insulation and teflon inner insulation, shield
 teflon outer and inner insulation, shield
 optional length AL from 0.5 to 50 m (2.5 m standard)

*1 ... if TC, only for insulation version of measuring end

Compensation wires (TC):

2× 0.22 mm², 4× 0.22 mm² stranded wire
 silicone outer and inner insulation
 fibreglass insulation with steel wire braiding
 teflon outer and inner insulation
 optional length AL from 0.5 to 50 m (2.5 m standard)

Flat connector (code KS, KM):

black ("J")
 green ("K")
 pink ("N")
 brown ("T")
 temperature resistance of connector -60 to +200 °C

Connecting thread (code H1...):

G3/8"
 G1/2"

Housing (according to EN 60529):

IP 67 (versions VV, KV)
 IP 50 (versions KS, KM)
 IP 64 (versions H1, H1G..)

5.2 Operation conditions

Maximal temperature at the end of sheath cable:

Ambient temperature at the area of flying leads outcome, connection of connection or compensating wires, connection of connector or sensor head cannot exceed 100 °C (120 °C short-term).

Measured media:

Applicability of the sensors for the specific medium depends on the stem material of the sensor.

Completion of measuring insert (S1, S2, S3, S4, S5) with temperature sensors:

Listed versions can be combined as a spare part with temperature sensors ModuTEMP® 70.

Humidity:

Sensors with fibreglass insulation of wires must be used in a dry environment.

5.3 Metrological parameters

Temperature sensors FlexiTEMP® 60 can be supplied:

- as sensors with calibration,
- as sensors without calibration.

Tolerance limits of accuracy classes are listed in EN 60751 for RTD and EN 60584-1 for TC. For thermocouples with connected wires according to EN 60584-3, allowed tolerance of thermoelectric voltage is increased by deviation of additional compensation/extension wires with accuracy class consistent with the primary TC. The initial tolerance is related to the initial calibration of the sensor. Drift of the sensor (RTD) meets the requirements of EN 60751, Sec. 6.5.3. To ensure accuracy of measurement, it is necessary to calibrate sensors periodically according to the operating parameters. Sensors can be supplied with calibration at several temperature points, according

to customer requirements.

5.4 Supplementary parameters

EMC (electromagnetic compatibility):

Sensors without transmitter do not contain any source of electromagnetic interference and they are not affected by electromagnetic fields. Sensors with transmitter meet the requirements of EN 61326-1.

Lifetime

Lifetime of the product cannot be exactly determined, it depends on the operational conditions. It is necessary to take into account that lifetime (reliability) of the temperature sensors may be significantly reduced e.g. by chemical corrosiveness or abrasion or erosion effects of the measured medium, effects of vibrations or shocks and surges (caused by flowing of the medium or transferred to the sensor from the external environment, such as from big rotary machines, etc.), cyclic temperature changes, fast temperature changes, use of the sensors at the upper limit of the temperature range, etc.

5.4.1 Version with transmitter

Sensors FlexiTEMP® 60 with codes VV, KS, KM, KV, H1 and H1... are designed for connection with transmitters for a DIN rail. Exchangeable measuring insert (standard for sensors ModuTEMP® 70) of versions with codes S2, S3, S4 can be completed with transmitters into head. This version is possible to apply for all sensor head types of ModuTEMP® 70 with outer diameter of transmitter 44 mm (span of fixing screws M4 - 33 mm).

Applicable transmitters

For range of transmitter see category optional accessories in transmitters for head mounting and the catalogue transmitters. For application in explosion hazard environment, transmitters with individual approval have to be selected.



For application with headmounted transmitter, observe also the requirements according to transmitter manual.

6. Tests, certificates, standards and marking

6.1 Tests and certificates

Temperature sensors FlexiTEMP® 60 have the following certificates and approvals:

For explosion hazard environment of gasses and dusts:

EC Certificate on type examination, No. FTZÚ 13 ATEX 0079X dated 25.6.2013 and Appendix No. 1 to the certificate dated 25.6.2018.

Certified are these types of resistance and thermocouple temperature sensors: T10...EI and T15...EI.

6.2 Standards and directives

RoHS:

2011/65/EU

Electromagnetic compatibility:

EN 61326-1

Sensors into explosion hazard environment:

EN 60079-0

EN 60079-11

6.3 Marking and type tag information

Marking on temperature sensors head:

Standard version (example):

- T1060... type number
- 1xPt100/B/4 number of sensors, sensor material, accuracy class, sensor connection
- 200 ..600 °C temperature range
- S.N. 11012345 serial number
- JSP, s.r.o. address of manufacturer
- Raisova 547
- 506 01 Jičín
- Czech Republic



logo JSP, s.r.o.

www.jsp.cz

website address



marking of conformity

Tag of sensor in version EI includes this information:

FTZÚ 13ATEX0079X

⊕ II 1/2G Ex ia IIC T6...Tx°C Ga/Gb

⊕ II 2D Ex ia IIIC T85°C...Tx°C Db

year of manufacture

		 www.jsp.cz	T1060 06 F3C S51 L10000 KV10000_ _11010 00 EI / ZP1234
FTZÚ 13ATEX0079X II 1/2G Ex ia IIC T6...Tx°C Ga/Gb II 2D Ex ia IIIC T85°C...Tx°C Db	1xPT100/B/4, -200...+600°C S.N. 11012345 IP68/IP00	JSP, s.r.o. Raisova 547 50601 Jičín Czech Republic	

7. Ordering information

7.1 Ordering table

Type		① ② ③ ④ ⑤ ⑥ ⑦ ⑧ ⑨ ○			
1. code	Description				
T1060	Sheath resistance temperature sensor				
T1560	Sheath thermocouple temperature sensor				
Temperature sensor		① ② ③ ④ ⑤ ⑥ ⑦ ⑧ ⑨ ○			
2. code	Resistance (RTD)	sheath material	max. temperature of use		
04	1× Pt100 / 2-wire	1.4404	up to 500 °C		
06	1× Pt100 / 4-wire	1.4404	up to 600 °C		
06HT	1× Pt100 / 4-wire only for code F7	Inconel 600	up to 700 °C		
06VR	1× Pt100 / 4-wire / increased resistance to vibration and shock only for code 06 F2 ... S5	1.4404	up to 500 °C		
07	2× Pt100 / 3-wire	1.4404	up to 600 °C		
08	2× Pt100 / 2-wire	1.4404	up to 500 °C		
09	2× Pt100 / 4-wire only for code S71 (diameter. 6 mm)	1.4404	up to 600 °C		
2. code	Thermocouple (TC)	sheath material	max. temperature of use		
20	1× "T" (Cu-CuNi), insulated	1.4541	-40 (-200) to +350 °C		
21	1× "J" (Fe-CuNi), insulated	1.4541	-40 to +800 °C		
61	2× "J" (Fe-CuNi), insulated, isolated junctions	1.4541	-40 to +800 °C		
22	1× "K" (NiCr-NiAl), insulated	Inconel 600	-40 (-200) to 1100 °C		
62	2× "K" (NiCr-NiAl), insulated, isolated junctions	Inconel 600	-40 (-200) to 1100 °C		
92	3× "K" (NiCr-NiAl), insulated, isolated junctions	Inconel 600	-40 (-200) to 1100 °C		
23	1× "N" (NiCrSi-NiSi), insulated	Inconel 600	-40 (-200) to 1100 °C		
63	2× "N" (NiCrSi-NiSi), insulated, isolated junctions	Inconel 600	-40 (-200) to 1100 °C		
22HT	1× "K" (NiCr-NiAl), insulated	Nicrobell/Pyrosil	-40 to 1300 °C		
62HT	2× "K" (NiCr-NiAl), insulated, isolated junctions	Nicrobell/Pyrosil	-40 to 1300 °C		
23HT	1× "N" (NiCrSi-NiSi), insulated	Nicrobell/Pyrosil	-40 to 1300 °C		
63HT	2× "N" (NiCrSi-NiSi), insulated, isolated junctions	Nicrobell/Pyrosil	-40 to 1300 °C		
...U	grounded version of junction TC				
99	other				
Accuracy class		① ② ③ ④ ⑤ ⑥ ⑦ ⑧ ⑨ ○			
3. code	Resistance (RTD) according to EN 60751	Inside wiring material	Measuring range		
F1	B not for code 06HT	Cu	-50 to +300 °C		
F2	B not for code 06HT	Cu	-70 to +500 °C		
F3	B only for codes 06, 07 a 09	Ni *1	-200 to +600 °C		
F7	B only for code 06HT	Ni *1	-200 to +700 °C		
F4	A only for codes 06, 07 a 09	Cu	-30 to +300 °C		
F5	A only for codes 06, 07 a 09	Cu	-100 to +450 °C		
F9	other				
3. code	Thermocouple (TC) according to EN 60584-1	Measuring range			
T8	3	-200 to +40 °C			
T7	2	-40 to 350 °C ("T") / 800 °C ("J") / 1200 °C ("K", "N")			
T6	1 not for TC "N" with code KV	-40 to 350 °C ("T") / 750 °C ("J") / 1000 °C ("K", "N")			

*1 - Not allowable to use two-wire connection because of nickel inner wiring.

Outer diameter of stem ① ② ③ ④ ⑤ ⑥ ⑦ ⑧ ⑨ ⑩

4. code	Dimension D	Maximal reference temperature for continuous operation			
		RTD	TC "J"	TC "K", "N" Inconel 600	TC "K", "N" Microbell/Pyrosil
S01	0,5 mm only for single TC		-	-	-
S11	0,8 mm only for single TC		-	-	-
S21	1 mm only for single TC		+260 °C	+700 °C	-
S31	1,5 mm only for single TC		+440 °C	+920 °C	-
S41	2 mm only for single TC		+440 °C	+920 °C	-
S51	3 mm	+400 °C	+520 °C	+1020 °C	+1100 °C
S61	4,5 mm only for TC	-	+620 °C	+1100 °C	-
S71	6 mm	+600 °C	+720 °C	+1100 °C	+1200 °C
S99	other				

Nominal length of stem ① ② ③ ④ ⑤ ⑥ ⑦ ⑧ ⑨ ⑩

5. code	Dimension L
L_	fill length in mm (min. length 100 mm)

Cold-end version of stem ① ② ③ ④ ⑤ ⑥ ⑦ ⑧ ⑨ ⑩

6. code	Description *1
VV	Flying leads standard length V=10 mm for stem diameter 1 to 2 mm and V=25 mm for stem diameter 3 to 6 mm
KS1	Flat single connector (plug), standard version only for TC with stem diameter 3 to 6 mm
KS2	Flat double connector (plug), standard version only for TC with stem diameter 3 to 6 mm
KM	Flat single connector (plug), mini version only for TC with stem diameter 1 to 3 mm
KV	Connected connecting cable (for RTD) or compensating cable (for TC) *2 not for TC 2x"N"
H1	Aluminium head type MA with ceramic terminal block, housing IP 64 not for double RTD – code 07
H1G3/8	Aluminium head type MA with ceramic terminal block, process connection G3/8", PN16, IP 64 not for double RTD – code 07, only for stem diameter 3 to 6 mm
H1G1/2	Aluminium head type MA with ceramic terminal block, process connection G1/2", PN16, IP 64 not for double RTD – code 07, only for stem diameter 3 to 6 mm
S1	Flange, diameter 42 mm with ceramic terminal block only for stem diameter 6 mm
S2	Flange, diameter 42 mm with set for mounting of transmitter on flange only for stem diameter 3 to 6 mm
S4	Flange, diameter 42 mm without terminal block, cable leads only for stem diameter 3 to 6 mm
S5	Flange, diameter 42 mm without terminal block, embedded pins (acc. to NAMUR) only for double temperature sensor
KL12	Connector LEMO diameter 12 mm (socket) it is necessary to specify the number, design and connection of pins, inot for sensor code 09 (2 x 4-wire.)
K9	other

*1 – Ambient temperature at the end of cable sheath (at flying leads outcome, connection of connection or compensation cables, connection of connector or sensor head) cannot exceed 100 °C (120 °C short-term). *2 – Tolerance of stem length and connection or compensation cables length is equal to the greater value of ±2 % of length or ±20 mm; accuracy class for TC wires according to EN 60584-3

Connection or compensation cable (compulsory for code KV, optional for codes KS, KM and H1)

In option with code KS or KM, the beginning of compensation wires is with flat connector (female) of specified type, specified connector has to be added in ordering code (see optional accessories – code Z2, Z3 or Z4).

Length of cable ① ② ③ ④ ⑤ ⑥ ⑦ ⑧ ⑨ ⑩

7. code	Dimension AL
200	200 mm

7. code	Dimension AL
1000	1000 mm
2500	2500 mm
5000	5000 mm
----	Other – fill length (step 100 mm)

Cable insulation ① ② ③ ④ ⑤ ⑥ ⑦ ⑧ ⑨ ○		
8. code	Wire insulation / shield / outer insulation / braiding	Ambient temperature of cable *1
I1010	Silicone / - / Silicone / - only for TC (not for "N")	-50 to +200 °C
I2010	FEP / - / Silicone / - only for RTD and TC 1x "N" acc. cl. 2	-50 to +200 °C
I2C10	FEP / copper wire braiding / Silicone / - only for RTD	-50 to +200 °C
I2C20	FEP / copper wire braiding / FEP / - only for RTD	-50 to +200 °C
I204N	FEP / - / glass fibres / stainless steel wire braiding only for RTD 2- and 4-wire	-50 to +200 °C
I3030	PFA / - / PFA / - only for TC	-200 to +260 °C
I3C30	PFA / copper wire braiding / PFA / - only for RTD 2- and 4-wire and TC "K"	-200 o +260 °C
I404Z	skelné vlákno / - / glass fibres / galvanized steel wire braiding only for TC (not for "N")	-20 to +350 °C
I808N	ceramic fibres / - / ceramic fibres / stainless steel wire braiding only for TC 1x "K"	-20 to +800 °C
I9999	other	

*1 – Ambient temperature at the end of cable sheath (at flying leads outcome, connection of connection or compensation cables, connection of connector or sensor head) cannot exceed 100 °C (120 °C short-term).

Wire termination ① ② ③ ④ ⑤ ⑥ ⑦ ⑧ ⑨ ○	
9. code	Description
01	Insulated pressing tube according to DIN 46228
02	Flat connector standard (plug) for single sensor, up to 220 °C only for TC
03	Flat connector standard (plug) for double sensor, up to 220 °C only for TC
04	Flat connector mini (plug) for single sensor, up to 220 °C only for TC
22	Flat connector standard (plug) for single sensor, ceramic up to 650 °C only for TC 1x"K"
24	Flat connector mini (plug) for single sensor, ceramic up to 650 °C only for TC 1x"K"
12	Connector LEMO diameter 12 mm (socket) it is necessary to specify the number, design and connection of pins, inot for sensor code 09 (2 × 4-wire.)
09	other

Optional versions and accessories ① ② ③ ④ ⑤ ⑥ ⑦ ⑧ ⑨ ●	
Code	Versions for explosive atmosphere of gasses or dusts
EI	Intrinsically safe version "Ex i" (Ex) II 1/2G Ex ia IIC T6...Tx°C Ga/Gb; (Ex) II 2D Ex ia IIIC T85°C...Tx°C Db
Code	Calibration in customer defined points, including certificate of calibration
KTE31A	Resistance temperature sensor calibration in three points in range -40 to +660 °C
KTE41A	Resistance temperature sensor calibration in four points in range -40 to +660 °C
KTE51A	Resistance temperature sensor calibration in five points in range -40 to +660 °C
KTE32AA	Thermocouple temperature sensor calibration in three points in range -40 to +660 °C
KTE42AA	Thermocouple temperature sensor calibration in four points in range -40 to +660 °C
KTE52AA	Thermocouple temperature sensor calibration in five points in range -40 to +660 °C
KTE32AB	Thermocouple temperature sensor calibration in three points in range -40 to +1100 °C

Code	Calibration in customer defined points, including certificate of calibration
KTE42AB	Thermocouple temperature sensor calibration in four points in range -40 to +1100 °C
KTE52AB	Thermocouple temperature sensor calibration in five points in range -40 to +1100 °C
KTE9	other
Code	Connectors, fuses of connectors and cables
Z2	Counterpart of connector (plug), standard version, for single sensor, up to 180 °C *1
Z3	Counterpart of connector (plug), standard version, for double sensor, up to 180 °C
Z4	Counterpart of connector (plug), mini version, for single sensor, up to 180 °C
Z32	Counterpart of connector (plug), standard version, for single sensor, ceramic up to 650 °C
Z34	Counterpart of connector (plug), mini version, for single sensor, ceramic up to 650 °C
PZ2	Counterpart of connector (rectangular panel plug), standard version, for single sensor, up to 180 °C
PZ4	Counterpart of connector (rectangular panel plug), mini version, for single sensor, up to 180 °C
PS	Lock of connection connectors standard, for single sensor
PM	Lock of connection connectors mini, for single sensor
PK1	Lock anti pull-up cable, for standard connectors for single sensor
PK2	Lock anti pull-up cable, for standard connectors for double sensor
PK3	Lock anti pull-up cable, for mini connectors for single sensor
ZL12	Counterpart of connector LEMO diameter 12 mm (plug)

*1 - Plug connector is possible to connect to standard or mini male connector.

Code	Fixing shift pipe unions, holders and distance sleeve
UPS3M12	Fixing shift pipe union for diameter 3 mm, connecting thread M12×1. *1
UPS4,5M12	Fixing shift pipe union for diameter 4.5 mm, connecting thread M12×1.5 *1
UPS6M20	Fixing shift pipe union for diameter 6 mm, connecting thread M20×1.5 *1
D3	Thermometer holder for wallmounting, material stainless steel (for head MA)
PV1	Distance sleeve diameter 8 mm, length 60 mm only for code S71 - stem diameter 6 mm

*1 - It is suitable only for non-flowing gas medium, free of mechanical stress including impacts and vibrations, where adjustable nominal length is required and is impossible to use fixing pipe unions PT because of high temperature.

Example of order:

T1560 22 T7 S51 L100 KV 1000 I1010 02 Z2 KTE32AB (-40, 500, 1000 °C) PS P1

Fixing shift pipe union for sheath temperature sensor

Version		P1 2 3	
1. code	Description	T _{MAX}	p _{MAX}
S	With stainless steel cutting ring, pipe union of stainless steel material *1	600 °C / 0,1 MPa	4 MPa / 100 °C
T	With PTFE sealing ring, pipe union of stainless steel material *2	200 °C / 0,1 MPa	0,6 MPa / 100 °C
B	With bayonet adaptor, supporting cap and spring, material nicked brass *3 only for sensor with outer diameter 2 mm (spring length 150 mm) and 3 mm (spring length 60 mm) with thread M12 or G1/4"		

*1 - Adjustable nominal length only for first time of mounting. *2 - Always adjustable nominal length. *3 - If bayonet connection including sensor is ordered, dimension K [mm] has to be specified.

Connection thread Z		P1 2 3	
2. code	Description		
M01	M8×1	only for sensors with diameter sheath 1 to 3 mm	
M02	M12×1,5	only for sensors with diameter sheath 3 to 6 mm (not for shift pipe union PB)	
M03	M16×1,5	only for sensors with diameter sheath 3 to 6 mm	
M04	M20×1,5	only for sensors with diameter sheath 3 to 6 mm	
M05	M12	only for sensors with diameter sheath 3 to 6 mm (only for shift pipe union PB)	
G01	G1/8"	only for sensors with diameter sheath 1 to 3 mm	
G02	G1/4"	only for sensors with diameter sheath 3 to 6 mm	
G03	G3/8"	only for sensors with diameter sheath 3 to 6 mm	
G04	G1/2"	only for sensors with diameter sheath 3 to 6 mm	

2. code	Description	
N01	1/8" NPT	only for sensors with diameter sheath 1 to 3 mm
N02	1/4" NPT	only for sensors with diameter sheath 3 to 6 mm
N03	3/8" NPT	only for sensors with diameter sheath 3 to 6 mm
N04	1/2" NPT	only for sensors with diameter sheath 3 to 6 mm





Outer diameter of stem sensor P 1 2 3

3. code	Description	
D15	1,5 mm	
D20	2 mm	
D30	3 mm	
D45	4,5 mm	
D60	6 mm	
G01	G1/8"	
G02	G1/4"	
G03	G3/8"	
G04	G1/2"	
N01	1/8" NPT	
N02	1/4" NPT	
N03	3/8" NPT	
N04	1/2" NPT	

Example of order:
PS M04 D60

8. Appendix

8.1 Declaration of conformity (standard version)

 <p>JSP Industrial Controls</p>	<p>Temperature Sensors – PC9270EN – 2022/08</p>						
<h2 style="margin: 0;"><u>EU DECLARATION OF CONFORMITY</u></h2>							
<p>We, JSP, s.r.o. Raisova 547, 506 01 Jičín, Czech Republic VAT No. CZ49286684</p>							
<p>declare under our sole responsibility that</p>							
<p>The Product: Temperature sensor series FlexiTEMP® 60</p>							
<p>Type/Model: T1060 ... standard version T1560 ... standard version</p>							
<p>is under the conditions specified in the manual in conformity with the following standards:</p>							
<table border="0" style="width: 100%;"> <tr> <th style="text-align: left; border-bottom: 1px solid black;">Czech Standards</th> </tr> <tr> <td>ČSN EN 61326-1:2013</td> </tr> </table>	Czech Standards	ČSN EN 61326-1:2013	<table border="0" style="width: 100%;"> <tr> <th style="text-align: left; border-bottom: 1px solid black;">European Standards</th> </tr> <tr> <td>EN 61326-1:2013</td> </tr> </table>	European Standards	EN 61326-1:2013		
Czech Standards							
ČSN EN 61326-1:2013							
European Standards							
EN 61326-1:2013							
<p>and following directives:</p>							
<table border="0" style="width: 100%;"> <tr> <th style="text-align: left; border-bottom: 1px solid black;">Czech Directives</th> </tr> <tr> <td>117/2016 Sb. as amended</td> </tr> <tr> <td>481/2012 Sb. as amended</td> </tr> </table>	Czech Directives	117/2016 Sb. as amended	481/2012 Sb. as amended	<table border="0" style="width: 100%;"> <tr> <th style="text-align: left; border-bottom: 1px solid black;">European Directives</th> </tr> <tr> <td>2014/30/EU as amended</td> </tr> <tr> <td>2011/65/EU as amended</td> </tr> </table>	European Directives	2014/30/EU as amended	2011/65/EU as amended
Czech Directives							
117/2016 Sb. as amended							
481/2012 Sb. as amended							
European Directives							
2014/30/EU as amended							
2011/65/EU as amended							
<table border="0" style="width: 100%;"> <tr> <td style="width: 35%; vertical-align: top;"> <p>Place of Issue: Jičín</p> <p>Date of Issue: 25. 08. 2022</p> </td> <td style="width: 65%; vertical-align: top;"> <div style="text-align: center; margin-bottom: 10px;">  </div> <p>Name and Signature of the Manufacturer's Representative: Ing. Vladimír Frýba</p> <p>Function: Chief executive Officer</p> </td> </tr> </table>		<p>Place of Issue: Jičín</p> <p>Date of Issue: 25. 08. 2022</p>	<div style="text-align: center; margin-bottom: 10px;">  </div> <p>Name and Signature of the Manufacturer's Representative: Ing. Vladimír Frýba</p> <p>Function: Chief executive Officer</p>				
<p>Place of Issue: Jičín</p> <p>Date of Issue: 25. 08. 2022</p>	<div style="text-align: center; margin-bottom: 10px;">  </div> <p>Name and Signature of the Manufacturer's Representative: Ing. Vladimír Frýba</p> <p>Function: Chief executive Officer</p>						
<table border="0" style="width: 100%;"> <tr> <td style="width: 30%;"> <p>JSP, s.r.o. Industrial Controls</p> </td> <td style="width: 30%;"> <p>CZ Raisova 547, 506 01 Jičín jsp@jsp.cz • +420 493 760 811</p> </td> <td style="width: 30%;"> <p>SK Krivá 23, 040 01 Košice predaj@jsp.sk</p> </td> <td style="width: 10%; text-align: right; vertical-align: bottom;"> <p>www.jsp.cz</p> </td> </tr> </table>		<p>JSP, s.r.o. Industrial Controls</p>	<p>CZ Raisova 547, 506 01 Jičín jsp@jsp.cz • +420 493 760 811</p>	<p>SK Krivá 23, 040 01 Košice predaj@jsp.sk</p>	<p>www.jsp.cz</p>		
<p>JSP, s.r.o. Industrial Controls</p>	<p>CZ Raisova 547, 506 01 Jičín jsp@jsp.cz • +420 493 760 811</p>	<p>SK Krivá 23, 040 01 Košice predaj@jsp.sk</p>	<p>www.jsp.cz</p>				

8.2 Declaration of conformity (explosion hazard environment version - codes EI)

Temperature Sensors - PC9262EN - 2022/08

EU DECLARATION OF CONFORMITY

We, **JSP, s.r.o.**
Raisova 547, 506 01 Jičín, Czech Republic
VAT No. CZ49286684

declare under our sole responsibility that

The Product: Temperature sensor series FlexiTEMP® 60
with intrinsically safe version Ex ia for use in potentially explosive gases and dust

Type/Model: T1060 ... EI
T1560 ... EI

is under the conditions specified in the manual in conformity with the following standards:

Czech Standards	European Standards
ČSN EN IEC 60079-0:2018	EN IEC 60079-0:2018
ČSN EN 60079-11:2012	EN 60079-11:2012
ČSN EN 61326-1:2013	EN 61326-1:2013

and following directives:

Czech Directives	European Directives
116/2016 Sb. as amended	2014/34/EU as amended
117/2016 Sb. as amended	2014/30/EU as amended
481/2012 Sb. as amended	2011/65/EU as amended

Physical Technical Testing Institute (FTZÚ), Notified Body No. 1026, Registration No. (VAT) CZ00577880, Pikartská 7, 716 07 Ostrava - Radvanice, Czech Republic, tested the product and issued: EC-Type Examination Certificate No. FTZÚ 13 ATEX 0079X, Date of Issue 25.06.2013, and supplement No. 1, Date of Issue 25.06.2018. This Notified Body issued Notification of quality safety No. FTZÚ 02 ATEX Q 011.

Place of Issue: Jičín

Date of Issue: 25.08. 2022

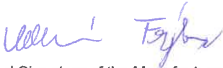

Name and Signature of the Manufacturer's Representative: Ing. Vladimír Frýba

Function: Chief executive Officer

JSP, s.r.o. | Raisova 547, Holínské Předměstí, 506 01 Jičín, Czech Republic
+420 493 760 811 | jsp@jsp.cz | www.jsp.cz



JSP Industrial Controls

JSP, s.r.o.

Raisova 547, 506 01 Jičín

Czech Republic

+420 493 760 811

jsp@jsp.cz

www.jsp.cz

JSP Service Line

+420 605 951 061

www.jsp.cz