

MANUAL

P5310, P5311

Low-Cost Programmable Transmitters with LHP Communication

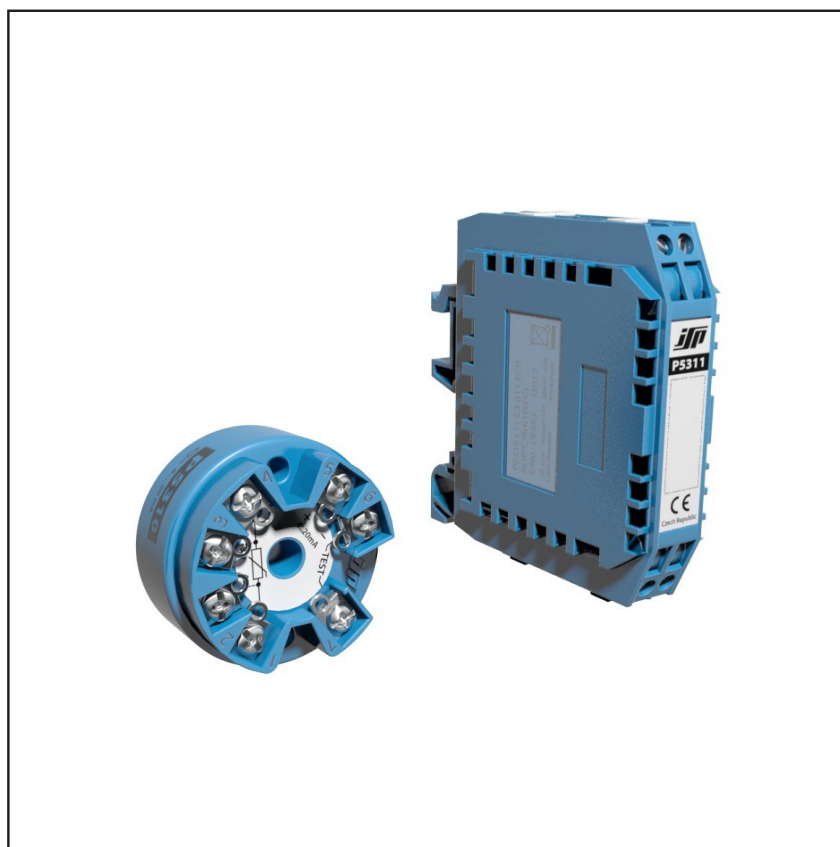

- One type of transmitter for all common resistance and thermocouple sensors
- Linearized output signal 4 to 20 mA
- Accuracy from 0.1 % for ranges down to 1/5 of the basic range
- Span adjustability from 1 % to 100 % of the basic range
- Galvanic isolation of input from output 1000 V AC (P5311)
- Adjustability by program LHPWinConf and standard HART modem or by field configurator LHPConf (HARTConf)
- High immunity against interference (industrial environment)
- Intrinsically safe version Ex II 1GD

This document applies to serial numbers 10090000 and higher.

Contents

1. General instructions and information	3
1.1 Symbols used.....	3
1.2 Safety cautions and warnings.....	3
1.3 Scope of delivery.....	3
1.4 Description of the delivery and packing.....	3
1.5 Storage.....	3
1.6 Installation and commissioning.....	3
1.7 Spare parts.....	3
1.8 Repairs.....	3
1.9 Warranty.....	3
2. End of service and disposal	3
2.1 End of service.....	3
2.2 Disposal.....	3
3. Product description	4
3.1 Application.....	4
3.2 Description.....	4
3.3 Dimensional drawings.....	5
3.4 Block diagram.....	5
4. Installation, operation and maintenance	6
4.1 Installation and commissioning.....	6
4.2 Description of setting and configuration using the communicator LHPWinCom.....	7
4.3 Description of setting and configuration using a handheld configurator LHPConf or HARTConf.....	7
4.4 Operation and maintenance.....	7
5. Product specifications	8
5.1 Technical specifications.....	8
5.2 Supplementary parameters.....	9
6. Tests, certificates and standards	9
6.1 Tests, certificates.....	9
6.2 Standards.....	9
6.3 Marking and type tag information.....	9
6.4 Limiting conditions of use of a transmitter in an intrinsically safe version (code E11).....	9
6.5 Limiting conditions of use of a transmitter in version with code EN2.....	10
7. Ordering information	10
7.1 Ordering table.....	10
8. Appendix	11
8.1 Declaration of conformity (explosion hazard environment version P5311 - code E11).....	11
8.2 Declaration of conformity (explosion hazard environment version P5310 - code EN2).....	12
8.3 Declaration of conformity (explosion hazard environment version P5311 - code EN2).....	13

1. General instructions and information

1.1 Symbols used



- Warning symbol; for safe use proceed according to the instructions



- The symbol CE approves conformity of the product with legal requirements



- Symbol "Output"



- Symbol "Power supply"



- This product does not belong to public waste and it is subjected to separate collection



- The product meets requirements for explosion hazard environment according to the further specification

LHP

- Remote communication protocol for reading and changing of the configuration

1.2 Safety cautions and warnings



The transmitter shall be powered from a safe voltage source that meets all requirements of the standard EN 61010-1 and installed in compliance with national requirements and standards providing safety.

The equipment may only be installed by a qualified personnel who are familiar with national and international laws, directives, standards and with the instructions manual. The instrument may not be used for other purposes than as specified in this instructions manual.

For elimination of a risk of injury from electric shock or fire the maximum operational parameters of the instrument may not be exceeded, particularly range of operating temperature because of exposure to heat from connected or surrounding technological equipment must not be exceeded!

The transmitter should be installed in suitable environment without any direct sunlight, occurrence of dust, high temperatures, mechanical vibrations and shocks and protected against rain and excessive moisture.

1.3 Scope of delivery

With the product is delivered:

- Manual for installation, operation and maintenance
- Certificate of calibration (only with calibrated transmitters)
- Copy of EC certificate on type examination ATEX (only transmitters for explosion hazard environment)

1.4 Description of the delivery and packing

The product is packaged in a protective cover and provided with an identification label with a mark of the output control. The product must not be exposed to direct rain, vibrations and shocks during transport.

1.5 Storage

The products shall be stored at temperatures from -40 to +80 °C without condensation of water vapours.

1.6 Installation and commissioning

During installation, commissioning, operation and maintenance follow the instructions in chapter 4.

1.7 Spare parts

Any of the compact parts of the product can be also ordered as a spare part if there are not required special procedures or technological operations for the exchange.

1.8 Repairs

Products are repaired by the manufacturer. The products for repair should be sent with description of the fault or defect in a packing that guarantees damping of shocks and vibrations and protects against damage during transport.

1.9 Warranty

Products are covered by a warranty for a period of 3 years from the delivery date on the delivery note. The manufacturer guarantees technical and operational parameters of the products within scope of the applicable documentation. Warranty period is specified with individual items and begins from the day of takeover of the goods by the purchaser or delivery to the carrier. Any claims concerning to defects of the goods together can be filed in writing with the manufacturer within the warranty period and the claimed product shall be presented. The claiming party shall give identification of the product, number of the delivery note and description of the fault or defect.

The manufacturer is not responsible for any defects caused by improper storage, incorrect connection, damages caused by external effects, in particular by effects of factors with excessive values, unqualified installation, improper operation or common wearing.

2. End of service and disposal

2.1 End of service



Dismounting and disposal of the device is possible after disconnecting of power supply voltage.

2.2 Disposal



The product does not contain any environmentally harmful parts. When disposing the packing and destroyed or irreparably damaged product proceed according to the local regulations.

3. Product description

P5310, P5311 Low-Cost Programmable Transmitters with LHP Communication

- One type of transmitter for all common resistance and thermocouple sensors
- Linearized output signal 4 to 20 mA
- Accuracy from 0.1 % for ranges down to 1/5 of the basic range
- Span adjustability from 1 % to 100 % of the basic range
- Galvanic isolation of input from output 1000 V AC (P5311)
- Adjustability by program LHPWinConf and standard HART modem or by field configurator LHPConf (HARTConf)
- High immunity against interference (industrial environment)
- Intrinsically safe version Ex II 1GD

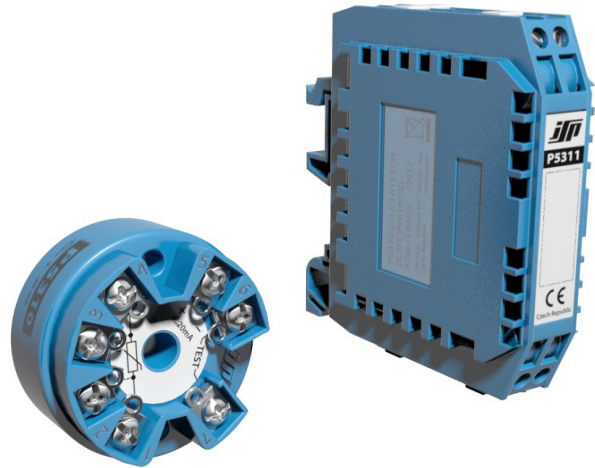

3.1 Application

Transmitters P5310 and P5311 are used for conversion of a resistance or voltage temperature signal from a resistance or thermocouple temperature sensor to a linearized current loop output signal 4 to 20 mA. The transmitter type H1x is designed for installation into an industrial sensor head type A or B according to DIN 43729. Inputs and outputs of the transmitters type P5310 are not galvanic-isolated, these types are suitable for resistance temperature sensors and simple systems. The transmitters type P5311 includes galvanic isolation of inputs and outputs and are suitable for also in applications with many measuring points and for thermocouples.

3.2 Description

Input signal, switched over according to the input configuration are processed by an A/D transmitter and transformed into a digital signal that is transferred to a micro-computer; according to the preset configuration and after filtration of noise there are calculated all measured variables. These values are then used for calculation of the primary variable (temperature) and according to selected range, the output current is also calculated.

One resistance sensor (two-, three- or four-wire) can be connected to the input. In case of a two-wire connection, entering of a constant value of the loop resistance compensation during configuration of the transmitter can compensate the resistance of input leads. In other cases, the leads resistance is compensated automatically.

A thermocouple can be also connected to the input. Temperature of the thermocouple cold junction is compensated according to configuration, either by the inner sensor of terminal block temperature or by the entered constant temperature. The inner sensor guarantees maximum accuracy and stability of cold junction temperature measurement. If required, compensation using an external sensor can be configured as well.

In addition to standard resistance sensors, there may be also processed signals of potentiometer positions that are measured in percents. One limit position is 0 % and the other is 100 %, independently on the value of the total resistance. In case there is necessary to measure position of the potentiometer as a resistance, there may be used the configuration for measurement of the resistance.

Output of the transmitter is analogue signal of the current loop 4 to 20 mA. The current output can be also used for testing of the current loop and associated apparatus. Communication is used mostly for configuration of the transmitter and is not designed for distances over approx. 10 m. The transmitter can be set up using a manual configurator LHPConf (HARTConf) or a PC with the program LHPWinConf and HART modem HARTMod (MH-02) or equivalent communication interface. The transmitter communicates through an own protocol LHP that is partially compatible with the protocol HART, uses the same connection, however, communication is guaranteed only for short distances and there are implemented only few commands. This interface is designed for changes of configuration. Continuous communication may influence accuracy of measurement.

3.3 Dimensional drawings

Version P531x H1x

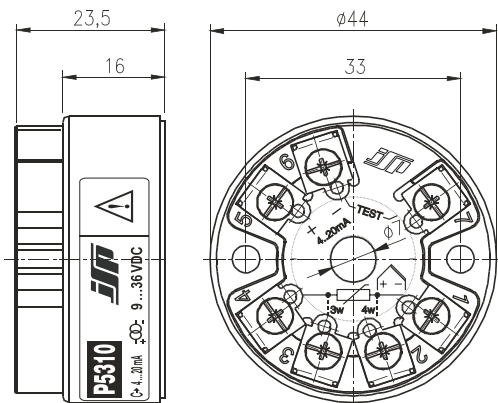

Version P531x L1x

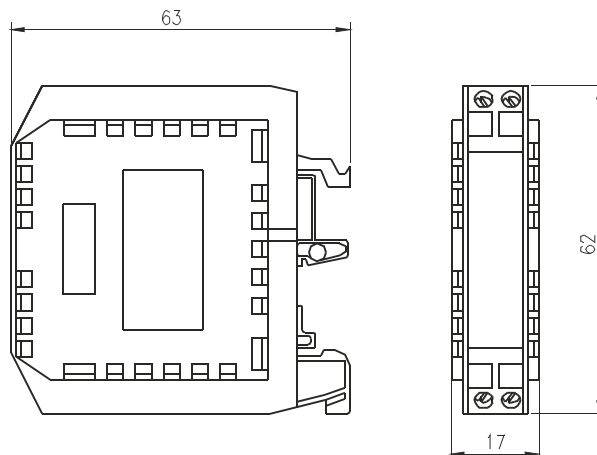

3.4 Block diagram

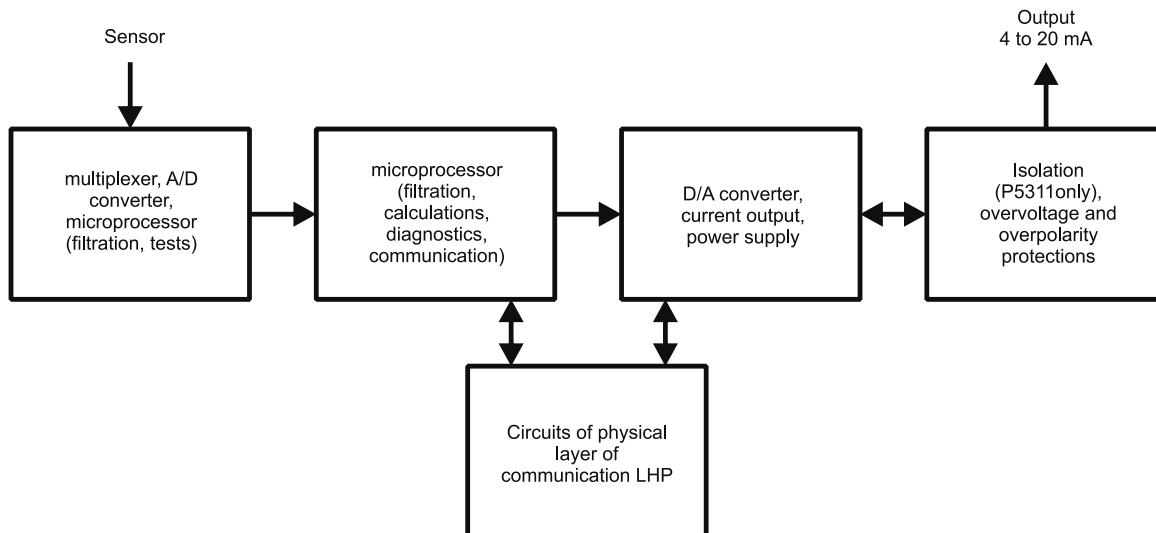

4. Installation, operation and maintenance

4.1 Installation and commissioning

4.1.1 General

After mounting and correct connection, switch on the power supply.

During the installation of transmitters in environment with higher level of interference, protection of transmitters against interference and induced overvoltage must be ensured.

According to the standard engineering practice, it is recommended to separate signal and power wires into separate gutters and use shielded signal cables with twisted wires. In case of outdoor wires, it is necessary to solve the overvoltage protection of the transmitter as a part of overall solution of protecting system from the effects of atmospheric electricity.

4.1.2 Special conditions for use of intrinsically safe version (code E11)

Ex II 1G Ex ia IIC T4-T6 Ga
Ex II 1D Ex ia IIIC T106°C Da



When installed in explosive environment of gasses or vapours, the transmitter shall be installed in a metal case with protection at least IP 20 to avoid electrostatic charging. Such case may be a metal temperature sensor head or a suitable metal installation box if it does not contain aluminium, magnesium, titanium nor zircon. During installation it is also necessary to respect other safety standards. The transmitter may be connected on its input and output sides only to suitable certified associated apparatus or simple apparatus in the sense of the standard EN 60079-11 with respecting of the limiting conditions. The transmitter may be installed in an environment with explosion hazard Zone 0, Zone 1 or Zone 2 only if all the related conditions are fulfilled. The equipment provides the necessary level of protection during normal operation and with one or two faults.

When installed in explosive environment of dusts, the transmitter shall be installed in a metal case to avoid electrostatic charging. Such case may be a metal temperature sensor head or a suitable metal installation box if it does not contain magnesium nor titanium. During installation it is also necessary to respect other safety standards. The transmitter may be connected on its input and output sides only to suitable certified associated apparatus or simple apparatus in the sense of the standard EN 60241-11 with respecting of the limiting conditions. The transmitter may be installed in an environment with explosion hazard Zone 20, Zone 21 or Zone 22 only if all the related conditions are fulfilled. The equipment provides the necessary level of protection during normal operation and with one or two faults.

Galvanic isolation of input and output electrical circuit is not faulty free isolation in terms of Intrinsically safety and it should be taken into account during the safety analysis of the system.

4.1.3 Special conditions for using of a transmitter in version (code EN2)

Ex II 3G Ex nA IIC T4 Gc



The transmitter shall be installed in a metal case with outlets and protection at least IP 54 (category 1 acc. to EN 60529) that meets requirement of mechanical resistance acc. to the standards EN 60079-0 and EN 60079-15. Such case may be for example the metal temperature sensor head with protection IP 54 or a suitable installation. During installation it is also necessary to respect other safety standards. Output and supply circuits or the transmitter can be connected only when no voltage is present! In case the temperature in place of the cable input is higher than 70 °C, a suitable cable and bushing shall be used and temperature acc. to par. 16.6 of the standard EN 60079-0 and must be marked on the outer side of the case! The transmitter may be installed in an hazardous areas in Zone 2. The equipment provides the necessary level of protection during normal operation.

4.1.4 Electrical connection

Version P531x H1x

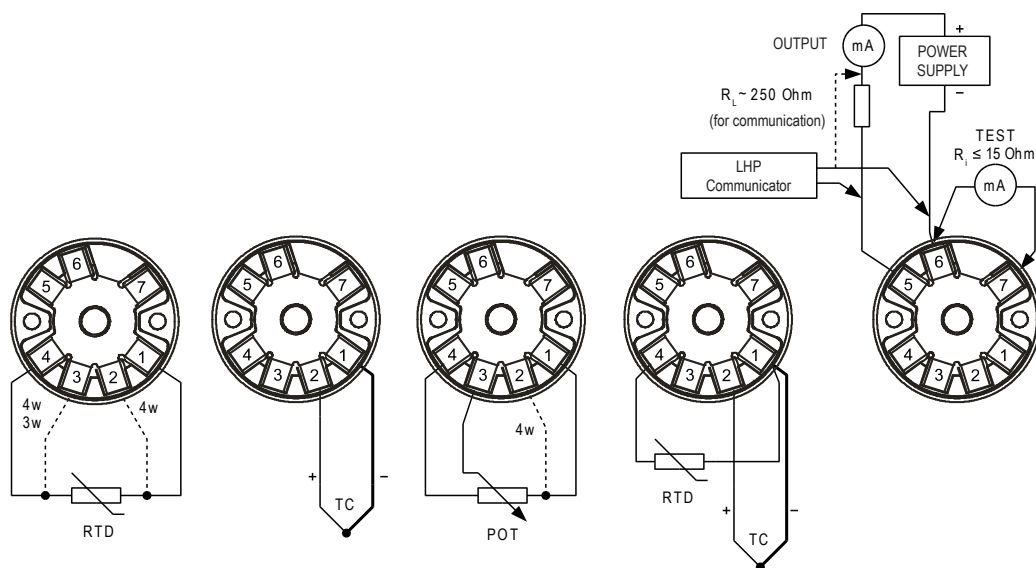

Version P531x L1x

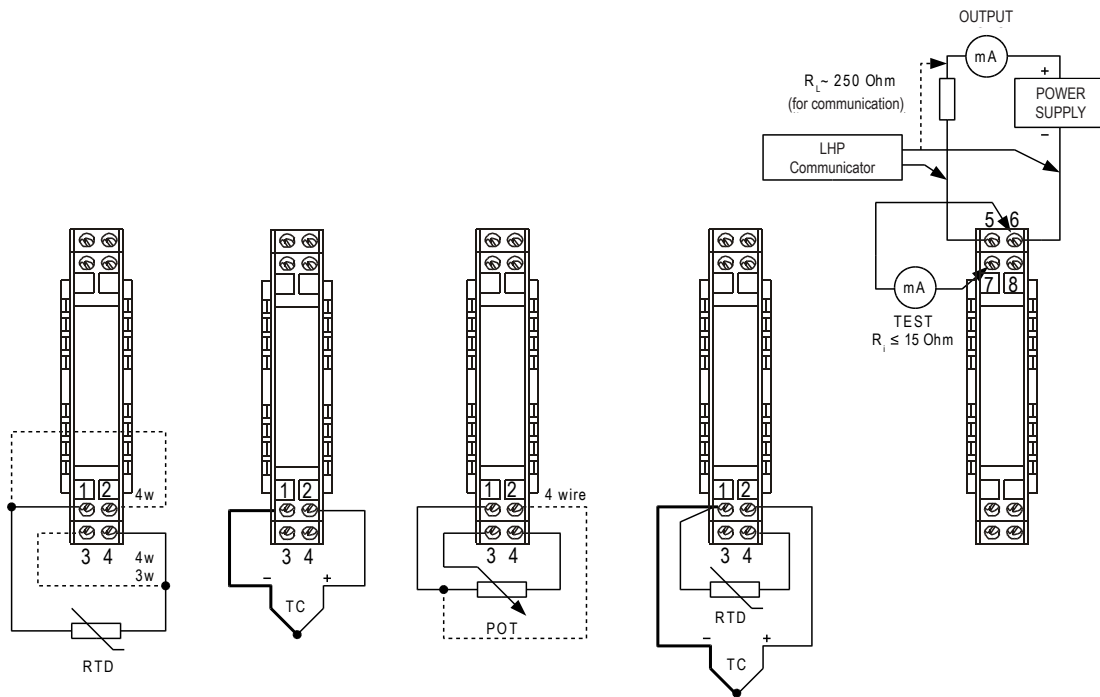

Numerals or letters may mark the terminals of the version P531x L1x:

Numerals	1	2	3	4	5	6	7	8
Letters	C	D	A	B	H	G	F	E

4.2 Description of setting and configuration using the communicator LHPWinCom

The communicator LHPWinCom consists of program LHPWinConf, modem HARTMod (MH-02) and connection cables. Before use is necessary to connect the modem to a PC using the connection cable, install and run the program LHPWinConf. Program finds the modem on the respective communication port by itself. In case, that the program issues a message that the modem is not connected, enter the respective port on the HART driver panel.

The program includes two main configuration panels. The panel "Calibrator Configuration" is used for fast setting of the range using a sensor simulator or using a calibrator. The panel "Keyboard Configuration" allows setting of all the available transmitter parameters directly on the keyboard without any necessity to use a calibrator. Individual steps of the optimal user procedure are given on both panels that should be followed. Configuration can be saved as a file or print it as a "Transmitter Configuration Protocol".

On the panel "Options" you can change the program language and run the fixed output mode. This mode changes the transmitter into a simulator of output current with the range 3.5 to 22 mA. In this mode the output current is determined by the entered value only and is not influenced by changes of the input quantity. The fixed output mode can be closed by the program button or by disconnecting of the transmitter power supply.

! Transmitters in version E11 or EN2 (Ex version) can be set up using the communicator LHPWinCom only if the transmitter, communicator and connected wires are installed out of explosion hazard environment!

4.3 Description of setting and configuration using a handheld configurator LHPConf or HARTConf

LHPConf and HARTConf are a field handheld configurators for setting of all parameters of transmitters with LHP communication. A detailed description of setting and control is given in the configurators instruction manual.

! Transmitters in version E11 or EN2 (Ex version) can be set up using the configurator LHPConf or HARTConf only if the transmitter, configurator and connected wires are installed out of explosion hazard environment!

4.4 Operation and maintenance

Provided that the instrument is installed correctly, the operator can read setting and measured values using a configurator. Setting of the instrument may be changed only if a sudden change of the output current cannot cause any failure of the technological equipment or regulation (switch over the possible regulator to manual control)!

The instrument does not need any maintenance.

5. Product specifications

5.1 Technical specifications

Supply voltage:

P5310	9 to 35 V _{SS}
P5311	11 to 35 V _{SS}
Version E11	11 to 30 V _{SS}

(internally protected against polarity inversion and short-term overvoltage)

Range of ambient temperatures: -40 to 85 °C

Reference ambient temperature: 23 ± 5 °C

Housing:

Version H1x	IP40, terminals IP00 after installation to the head the housing is given by the design of the head
Version L1x	IP20

Humidity:

Version H1x	0 to 100 % RH with condensation after installation to the head
Version L1x	10 to 80 % RH without condensation

Connection of wires:

Screw terminals for cross section 0,5 to 1,5 mm², torque 0,5 Nm.

Warm-up time: 5 s

Time for re-programming of range using a PC: 5 s

Time for re-programming of sensor type using a PC: 5 s

Type of DIN rail: TS 35 according to DIN 46277

Dimensions (HxWxD):

H1x	Ø 44 x 24 mm
L1x	17.5 x 62.5 x 64 mm

Material of cases:

H1x	polycarbonate
L1x	polyamide

Weight:

H1x, L1x	40 g
----------	------

Working position: arbitrary

Input

Input ranges:

Input type	Basic range	Standard
RTD input	0 to 400 Ohm	---
RTD input	0 to 4000 Ohm	---
potentiometer	40 to 400 Ohm	---
potentiometer	400 to 4000 Ohm	---
voltage input	-15 to 70 mV	---
Pt100	-200 to 850 °C	IEC 60751
Pt500	-200 to 850 °C	IEC 60751
Pt1000	-200 to 850 °C	IEC 60751
Ni100	-60 to 250 °C	DIN 43760
Ni1000	-60 to 250 °C	DIN 43760
thermocouple "J"	-200 to 1200 °C	IEC 584-1
thermocouple "K"	-200 to 1300 °C	IEC 584-1
thermocouple "N"	-200 to 1300 °C	IEC 584-1

thermocouple "R"	-50 to 1700 °C	IEC 584-1
thermocouple "S"	-50 to 1700 °C	IEC 584-1
thermocouple "T"	-250 to 400 °C	IEC 584-1
thermocouple "B"	100 to 1800 °C*	IEC 584-1
thermocouple "E"	-200 to 950 °C	IEC 584-1
thermocouple "L"	-200 to 900 °C	DIN 43710
thermocouple "C"	0 to 2300 °C	N.I.S.T. Monograph 175

* ... range can be set from 0 °C

Digital accuracy:

Range 0 to 400 Ohm	≤ ±0.1 % SR or ≤ ±0.08 Ohm or corresponding temperature
Range 0 to 4000 Ohm	≤ ±0.1 % SR or ≤ ±0.8 Ohm or corresponding temperature
Range -15 to 70 mV	≤ ±0.1 % SR or ≤ ±0.02 mV or corresponding temperature

(the greatest value is valid; accuracy of measured value of digital output LHP)

Input signal:

Resistance signal of temperature sensor or potentiometer, voltage signal of thermocouple

Sensor connection:

Resistance sensor	two-, three-, four-wire
Voltage sensor (TC)	two-wire
Potentiometer	three-wire or four-wire
Compensation using an external sensor	two-wire

Maximum wire resistance for resistance ranges :

< 20 Ohm (each wire)

Current through resistance sensor:

< 0.15 mA

Input overloading:

Max. 24 VDC or max. 18 mA between any inputs (max. 60 s)

Cold junction compensation error:

< ±1 °C

Effect of wire resistance for resistance ranges:

Two-wire connection	can be compensated by constant value
Three-wire connection	no effect with identical values of wire resistance
Four-wire connection	no effect with specified wire resistance range

Input resistance: > 10 MOhm

Output

Output signal:

Two-wire 4 to 20 mA or 20 to 4 mA

Total measurement error on the analogue output of P5310:

Range 0 to 400 Ohm	≤ ±0.1 % SR or ≤ ±0.08 Ohm or corresponding temperature
Range 0 to 4000 Ohm	≤ ±0.1 % SR or ≤ ±0.8 Ohm or corresponding temperature
Range -15 to 70 mV	≤ ±0.1 % SR or ≤ ±0.02 mV or corresponding temperature
Range Pt100, Pt1000, Ni100, Ni1000	≤ ±0.1 % SR or ≤ ±0.2 °C
Range Pt500	≤ ±0.1 % SR or ≤ ±0.4 °C
Range TC J, K, T, E, L	typ. ≤ ± 0.1 % SR or 0.5 °C
Range TC R, S, B, C	typ. ≤ ± 0.1 % SR or 2 °C

(the greatest value is valid)

Total measurement error on the analogue output of P5311:

- Range 0 to 400 Ohm $\leq \pm 0.15\%$ SR or $\leq \pm 0.12$ Ohm or corresponding temperature
- Range 0 to 4000 Ohm $\leq \pm 0.15\%$ SR or $\leq \pm 1.2$ Ohm or corresponding temperature
- Range -15 to 70 mV $\leq \pm 0.15\%$ SR or $\leq \pm 0.03$ mV corresponding temperature
- Range Pt100, Pt1000, Ni100, Ni1000 $\leq \pm 0.15\%$ SR or $\leq \pm 0.3$ °C
- Range Pt500 $\leq \pm 0.15\%$ SR or $\leq \pm 0.6$ °C
- Range TC J, K, T, E, L typ. $\leq \pm 0.15\%$ SR or 0.5 °C
- Range TC R, S, B, C typ. $\leq \pm 0.15\%$ SR or 2 °C (the greatest value is valid)

Characteristics:

Linear with temperature or linear with input quantity, other upon request

Adjustability of the range:

$\pm 1\%$ to $\pm 100\%$ of the input range

Adjustability:

Inside the input range (the given measurement errors apply for suppression of the beginning $\leq 100\%$ of the range)

Time constant (95 %):

Adjustable 0.5 to 60 s (2 measurements per second)

Load resistance: $R_L [\text{Ohm}] \leq (U_N [\text{V}] - 9) / 0.022$

Electric strength of galvanic isolation of P5311:

1000 VAC (test)

Isolation resistance of galvanic isolation of P5311:

Min. 100 MOhm

5.2 Supplementary parameters

Output current limitation:

Signal 3.8 to 20.5 mA acc. to NAMUR NE43
Limitation of error current to approx. 22 mA

Indication of sensor or transmitter error:

Optionally by current > 21 mA or < 3.6 mA according to NAMUR NE43

Supply voltage effect: $\leq \pm 0.005\%$ / V

Influence of ambient temperature changes:

Range 0 to 400 Ohm ($\leq \pm 0.1\%$ SR or $\leq \pm 0.08$ Ohm or corresponding temperature) / 10 °C
 Range 0 to 4000 Ohm ($\leq \pm 0.1\%$ SR or $\leq \pm 0.8$ Ohm or corresponding temperature) / 10 °C
 Range -15 to 70 mV ($\leq \pm 0.1\%$ SR or $\leq \pm 0.02$ mV or corresponding temperature) / 10 °C
 (the greatest value is valid)

Long-term stability:

$\leq \pm 0.1\%$ of the preset range per 2 years

Electromagnetic compatibility:

Radiation and immunity acc. to EN 61326-1 (Industrial environment)

MV ... measured value

SR ... span of preset range

6. Tests, certificates and standards

6.1 Tests, certificates

Electromagnetic compatibility

Emission and immunity acc. to EN 61326-2-3

Intrinsically safe version (option EI1)

Certificate FTZÚ 06 ATEX 0353X + Supplements 1, 2 and 3

Version “n” (version EN2)

Producer assessment ZV100006 (P5311) and ZV100011 (P5310)

6.2 Standards

Transmitter is designed and manufactured according these standards:

EN 61010-1

Version EI1:

EN 60079-0

EN 60079-11

Version EN2:

EN 60079-0

EN 60079-15

6.3 Marking and type tag information

Standard version:

Standard version:

P5311

type number

Model:

version

S/No:

serial number

Czech Republic

country of origin



www.jsp.cz

logo of JSP, s.r.o.

contact for manufacturer

Tag of version EI1 includes further:

II 1G Ex ia IIC T4-T6 Ga
 II 1D Ex ia IIIC T106°C Da
 year of manufacture
 number of ATEX certificate

Tag of version EN2 includes further:

II 3G Ex nA IIC T4 Gc
 $-40\text{ °C} \leq T_a \leq 85\text{ °C}$
 year of manufacture
 document number of producer assessment report

6.4 Limiting conditions of use of a transmitter in an intrinsically safe version (code EI1)

Relation between the temperature class and ambient temperature:

T4 (T106 °C)	$-40\text{ °C} < T_{\text{amb}} < 85\text{ °C}$
T5 (T76 °C)	$-40\text{ °C} < T_{\text{amb}} < 55\text{ °C}$
T6 (T61 °C)	$-40\text{ °C} < T_{\text{amb}} < 40\text{ °C}$

Output (current loop, terminal 5 and 6):

$$U_i = 30 \text{ VDC}$$

$$I_i = 100 \text{ mA}$$

$$P_i = 0.9 \text{ W}$$

$$L_i = 350 \text{ }\mu\text{H}$$

$$C_i = 0 \text{ nF}$$

Output test (terminal 6 and 7; it is designed only for temporary connection of a multimeter):

$$U_o = 30 \text{ VDC}$$

$$I_o = 100 \text{ mA}$$

$$P_o = 0.9 \text{ W}$$

$$L_o = 100 \text{ }\mu\text{H}$$

$$C_o = 0 \text{ nF}$$

Input for a sensor:

$$U_o = 6.6 \text{ VDC}$$

$$I_o = 21 \text{ mA}$$

$$P_o = 0.034 \text{ W}$$

$$L_o = 70 \text{ mH}$$

$$C_o = 1 \text{ }\mu\text{F}$$

For other conditions see paragraph 4.1.2.

6.5 Limiting conditions of use of a transmitter in version with code EN2

See paragraph 4.1.3.

7. Ordering information

7.1 Ordering table

Type	Description
• P5310	Low-cost programmable transmitter with LHP communication without galvanic isolation (accuracy 0,1 %)
• P5311	Low-cost programmable transmitter with LHP communication with galvanic isolation (accuracy 0,15 %)
Code	Version
• H10	Into head B according to DIN, universal for resistance sensors and thermocouples
• H11	Into head B according to DIN, only for resistance sensors
• L10	On the rail TS 35, universal for resistance sensors and thermocouples
• L11	On the rail TS 35, only for resistance sensors
Code	Setting requirements
• NR	Without requirements for the range and input setting (preset - Pt100, three-wire connection of sensor, 0 to 100 °C)
• QR	Range and other parameters setting according to configuration sheet DB2298
Code	Calibration
KPP5	Transmitter calibration in five points evenly distributed in setting range
Code	Optional version
◦ E11	Intrinsically safe version (Ex) II 1G Ex ia IIC T4-T6 Ga, (Ex) II 1D Ex ia IIIC T106°C Da (only for version P5311 H1x)
◦ EN2	Non-incendive design (Ex) II 3G Ex nA IIC T4 Gc
Code	Optional accessories
• LHPWinCom USB1	Set of configuration program LHPWinConf (CZ+EN) for PC, modem HARTMod and interface USB-RS232C
• LHPConf	Field configurator for LHP transmitters, function of transmitter supply, without charging
• HARTConf	HART-USB modem and field communicator for LHP and HART transmitters, function of transmitter supply supplied from USB or inbuilt accumulator, charged from USB
• HARTMod	HART modem with interface RS232 and with galvanic isolation
• USB-RS232C	Communication interface RS232 for to USB port of the PC
• PT1000A	Compensation resistor Pt1000 (-30 to +150 °C) for external compensation of thermocouple
S51	Box for wall mounting of one transmitter to explosive atmosphere (IP 68) (Ex) II 2G Ex db IIC T6, T5 Gb + (Ex) II 2D Ex tb IIIC T50/60/80°C Db (2 cable glands KMEx have to be ordered)
S52	Box for wall mounting of one transmitter with LED display to explosive atmosphere (IP 68) (Ex) II 2G Ex db IIC T6, T5 Gb + (Ex) II 2D Ex tb IIIC T50/60/80°C Db (2 cable glands KMEx have to be ordered)
• S54	Wall mounted box (100x100x58 mm), housing IP 65 (for H1x versions, not for E11, EN2) ¹⁾
• S55	Wall mounted box (170x145x85 mm), housing IP 55 (for L1x versions, not for E11, EN2) ²⁾
• S56	Wall mounted box (100x100x58 mm), housing IP 65 (for H1x versions, not for E11, EN2) ³⁾
• VH1	Cap for head form B for transmitter mounting (for H1x versions)
• APT1	Adapter for flat head
• KME1	Cable outlet, nickel silver, Ex d, M20x1.5, IP 68, for fixed assembly cable with diameter 4.5 to 8.5 mm
• KME2	Cable outlet, nickel silver, Ex d, M20x1.5, IP 68, for fixed assembly cable with diameter 7 to 12 mm
KME3	Cable outlet, stainless steel, Ex d, M20x1.5, IP 68, for fixed assembly cable with diameter 4 to 8 mm
KME5	Cable outlet, polyamide, Ex ie, M20x1.5, IP 68, for fixed assembly cable with diameter 5 to 9 mm, operating temperature -20 to +95 °C
KME6	Cable outlet, polyamide, Ex ie, M20x1.5, IP 68, for fixed assembly cable with diameter 6.5 to 12 mm, operating temperature -20 to +95 °C
3-year warranty	
Example of order: P5311 H11 QR For code QR configuration sheet DB2298 is required to the order.	

- ... Ex stock version ◦ ... Marked version can be dispatched up to 5 working days (with calibration up to two weeks)
- ¹⁾ ... Possibility of installing one transmitter ²⁾ ... Possibility of installing up to three transmitters
- ³⁾ ... Possibility of installing two transmitters

8. Appendix

8.1 Declaration of conformity (explosion hazard environment version P5311 - code EI1)



JSP Industrial Controls

Transmitters – PB9198EN – 2019/04

EU DECLARATION OF CONFORMITY

We, JSP, s.r.o.
Raisova 547, 506 01 Jičín, Czech Republic
VAT No. CZ49286684

declare under our sole responsibility that

The Product: Universal Programmable Two-wire Transmitter

Type/Model: P5311 H1x, version EI1

is under the conditions specified in the manual in conformity with the following standards:

Czech Standards	European Standards
ČSN EN 61326-2-3:2013	EN 61326-2-3:2012
ČSN EN 60079-0:2013	EN 60079-0:2012
ČSN EN 60079-11:2012	EN 60079-11:2012

and following directives:

Czech Directives	European Directives
117/2016 Sb. as amended	2014/30/EU as amended
116/2016 Sb. as amended	2014/34/EU as amended
481/2012 Sb. as amended	2011/65/EU as amended

Physical Technical Testing Institute (FTZÚ), Notified Body No. 1026, Registration No. (VAT) CZ00577880, Pikartská 7, 716 07 Ostrava - Radvanice, Czech Republic, tested the product and issued: EC-Type Examination Certificate No. FTZÚ 06 ATEX 0353 X, Date of Issue 19.04.2007 with Amendment No.4, Date of Issue 03.01.2017 and Quality Assurance Notification No. FTZÚ 02 ATEX Q011. No changes are required to enable compliance with the current version of the standards.

No changes of the product were required to enable compliance with the above updated standards.

Place of Issue: Jičín

Name and Signature of the Manufacturer's Representative: Ing. Vladimír Frýba

Date of Issue: 12.04.2019

Function: Production Director

8.2 Declaration of conformity (explosion hazard environment version P5310 - code EN2)



Transmitters – PB9168EN – 2019/04

EU DECLARATION OF CONFORMITY

We, JSP, s.r.o.
Raisova 547, 506 01 Jičín, Czech Republic
VAT No. CZ49286684

declare under our sole responsibility that

The Product: Universal Programmable Two-wire Transmitter

Type/Model: P5310 H1x, L1x, version EN2

is under the conditions specified in the manual in conformity with the following standards:

Czech Standards	European Standards
ČSN EN 61326-2-3:2013	EN 61326-2-3:2012
ČSN EN 60079-15:2010	EN 60079-15:2010
ČSN EN 60079-0:2013	EN 60079-0:2012

and following directives:

Czech Directives	European Directives
117/2016 Sb. as amended	2014/30/EU as amended
116/2016 Sb. as amended	2014/34/EU as amended
481/2012 Sb. as amended	2011/65/EU as amended

Conformity is assured by applying the procedure of Annex VIII of the Directive 2014/34/EU.

Manufacturer made conformity assessment according to the standard EN 60079-15 in report ZV100011 date 09.07.2013.

Place of Issue: Jičín

Name and Signature of the Manufacturer's Representative: Ing. Vladimír Fryba

Date of Issue: 12.04.2019

Function: Production Director

JSP, s.r.o.
Industrial Controls

CZ Raisova 547, 506 01 Jičín
+420 493 760 811 • jsp@jsp.cz

SK Karloveská 63, 841 04 Bratislava
+421 2 6030 1080 • predaj@jsp.sk

www.jsp.cz

8.3 Declaration of conformity (explosion hazard environment version P5311 - code EN2)

EU DECLARATION OF CONFORMITY

We, JSP, s.r.o.
Raisova 547, 506 01 Jičín, Czech Republic
VAT No. CZ49286684

declare under our sole responsibility that

The Product: Universal Programmable Two-wire Transmitter

Type/Model: P5311 H1x, L1x, version EN2

is under the conditions specified in the manual in conformity with the following standards:

Czech Standards	European Standards
ČSN EN 61326-2-3:2013	EN 61326-2-3:2012
ČSN EN 60079-15:2010	EN 60079-15:2010
ČSN EN 60079-0:2013	EN 60079-0:2012

and following directives:

Czech Directives	European Directives
117/2016 Sb. as amended	2014/30/EU as amended
116/2016 Sb. as amended	2014/34/EU as amended
481/2012 Sb. as amended	2011/65/EU as amended

Conformity is assured by applying the procedure of Annex VIII of the Directive 2014/34/EU.

Manufacturer made conformity assessment according to the standard EN 60079-15 in report ZV100006 date 09.07.2013.

Place of Issue: Jičín

Name and Signature of the Manufacturer's Representative: Ing. Vladimír Frýba

Date of Issue: 12.04.2019

Function: Production Director





JSP Industrial Controls

JSP, s.r.o. | Raisova 547, 506 01 Jičín, Czech Republic
+420 493 760 811 | export@jsp.cz | www.jsp.cz

Your Supplier: